

# LANCE & FORM 90° (FORM-UP)

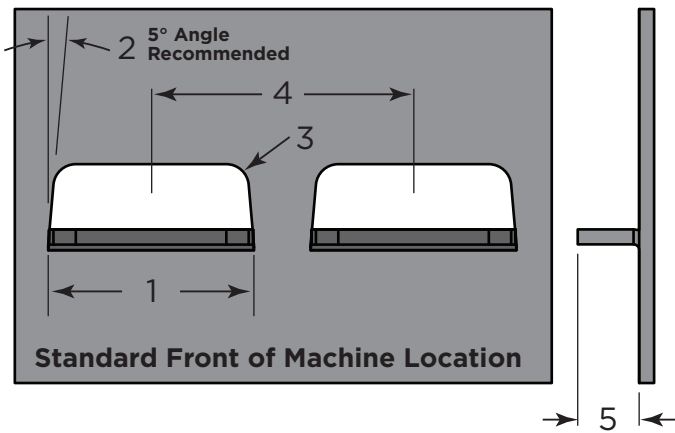
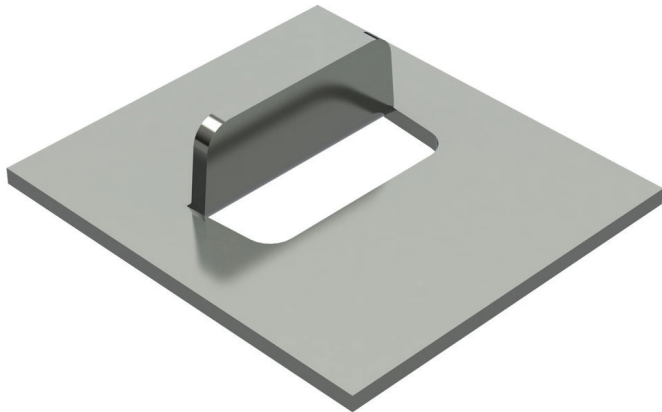

- The standard tolerance on the bend is +0°-3° for MS & +0°-5° for SS.
- If the tool needs relief, an alternate design may be required.

| Questions | Changes | Comments |
|-----------|---------|----------|
|           |         |          |

| Contact Information |
|---------------------|
| Your Name _____     |
| Phone _____         |
| Company _____       |

| Order Information  |
|--|
| <input type="checkbox"/> <b>Form-Up</b><br><i>Form down available, consult Tooling Technician.</i> |
| Dim. 1 _____   |
| Dim. 2 _____   |
| Dim. 3 _____   |
| Dim. 4 _____   |
| Dim. 5 _____   |
| <b>Material Type</b><br>(eg: Aluminum) _____   |
| <b>Material Thickness</b><br>(eg: 1.6mm or .060) _____   |
| <b>Machine Type</b><br>(eg: Amada-Pega 357) _____  |
| <b>Auto Index:</b> <input type="checkbox"/> Yes <input type="checkbox"/> No                        |
| <b>High Form Station:</b> <input type="checkbox"/> Yes <input type="checkbox"/> No                 |

 **Click to email form. Attach file to ensure quote accuracy (relief may be required).**