



WT-STYLE PRESS BRAKE TOOLING

2026

My Account

by Wilson Tool International

Wilson Tool Customers have 24/7 access to their account online! My Account allows for:

- Access to Drawings
- Viewing Invoices
- Tracking Packages
- Reviewing Order History

wilsontool.com/MyAccount



CONNECT WITH WILSON TOOL

Keep up with everything that's new at Wilson Tool International! Visit our website or find us on social media for the latest information, news, videos and product releases.



TERMS AND CONDITIONS

Please note, all orders are subject to Wilson Tool International's Terms and Conditions which include pricing, payment, delivery, warranties, and our return policy. To view our full Terms and Conditions, visit wilsontool.com/en-us/terms-conditions.

Information in this catalog, including pricing and product availability, is subject to change. Wilson Tool International reserves the right to modify data, specifications, and illustrations without notice and are not liable for errors or printing mistakes.



WT-STYLE PRESS BRAKE TOOLING

About Wilson Tool	4-5	Sets & Holders.....	52-58
WT-Style Tooling.....	6	Replaceable Radius Punches.....	52
Push Button Technology.....	7	Offset Punch and Die Sets.....	53
Punches.....	8-17	Flattening Spacer Blocks	54
120mm Family Punches	8-10	Two Stage Hemming	54-55
86° Swan Neck.....	8	Flattening Set	55
80° Swan Neck Thin Tip.....	8	Punch Holders	56-57
86° Gooseneck.....	9	Die Holder	57
28° Acute with Relief.....	9	Urethane Die Holders and Pads	58
60° Pointed	10	Special Tooling	59-80
28° Hemming.....	10	Reference Info	81-86
163mm Family Punches.....	11	Air Bending Force Charts	81-82
200mm Family Punches.....	12	Tonnage Estimates	83
220mm Family Punches	13-16	Specials Checklist	84
86° Swan Neck.....	13	Typical Press Setup	85
86° Gooseneck.....	14	Tip Modifications.....	86
28° Acute with Relief.....	15	Ear Piece.....	86
60° Pointed	16	Accessories	87-91
240mm Family Punches	17		
28° Hemming.....	17		
Bend Limit Graphs	18-39		
Dies.....	40-49		
Full Body Dies – 100mm Tall.....	40-44		
Full Body Dies – 120mm Tall	43-44		
Relieved Dies – 100mm Tall.....	45		
55mm Tall Dies.....	46		
Thin Body Dies – 100mm Tall	47		
V-Series Black (VSB) Dies	48-51		



Laser Marking

Wilson Tool clearly laser marks all of our WT-Style punches and dies with detail for easy tool identification.

Prices and product availability are subject to change without notice.

ABOUT WILSON TOOL INTERNATIONAL

From humble beginnings in a small manufacturing facility in St. Paul, Minnesota, Wilson Tool International has added manufacturing facilities and sales channels around the world to better serve our thousands of global customers. Throughout our expansion, our mission has never wavered — we continue to offer products and services that help you be more successful. Every product you buy, every employee with whom you communicate, and every training event you attend, are designed to help customers just like you be more successful.

At Wilson Tool, we continue to invest in your success through constant innovation. Our tooling and solutions represent decades of knowledge and experience in assisting manufacturers resolve their most challenging fabrication issues. We understand that no two jobs are the same. Change is the only constant in manufacturing. So, working with a tooling supplier who's flexible, nimble, and knowledgeable is important.

Our goal is to deliver exceptional **customer service** along with the most reliable and innovative products and solutions so that our **customers** can be more successful.

When you have a challenge, reach out to us. At Wilson Tool we are more than tools... we are solutions. Your local Sales Engineer is available in person, by phone and through e-mail. Let us put our many decades of expertise to the test. We will work with you to find the best possible solution to whatever challenge you may be facing. And every order comes with our guarantee to outperform your current tooling.

From all of us at Wilson Tool, thank you for the trust you have placed in us to provide products and services that are critical to your business. We look forward to your continued success as we head into the future.



BENDING

Wilson Tool's Bending division delivers the most complete line of tooling and clamping solutions available anywhere.

Whether you use American, European, WT, Bystronic or LVD-style precision or conventional tooling, Wilson Tool has a solution for you. Our clamping options cover these styles as well. With hydraulic push button, quick release mechanical or standard manual clamps, we have a clamping solution for any style of machine or budget. And our custom tooling manufacturing capabilities are the envy of the industry with innovative solutions for complex bending challenges. With manufacturing facilities located in the USA and Canada, our delivery times to North American fabricators are the fastest in the industry.



STAMPING



Wilson Tool's Stamping division, Impax Tooling Solutions®, offers high quality punch and die components, accessories and retainers for the stamping industry.

Innovative products such as our HP Accu-Lock® Retainer Inserts and extensive coating options, combined with our world-class customer service, have enabled us to quickly grow into a world-class provider. With a direct sales force throughout North America, we deliver products straight from the factory to you, enabling the fastest deliveries in the industry. Our custom tooling expertise is second to none with many customers coming to us for their most difficult stamping challenges.

PUNCHING

Wilson Tool's Punching division continues to drive the industry with new levels of quality, delivery, service and innovation.

From the early days of Series 80 to the Wilson Wheel® Family to EXP® technology, our punching division has been the industry-leading innovation driver. Combined with the most experienced customer support professionals in the industry, Wilson Tool continues to raise the bar. Thick turret, TRUMPF-style, Salvagnini-style, or any other style of punch press you may be using, Wilson Tool offers the most complete line of tooling solutions available today.



TRUMPF is a trademark of TRUMPF GmbH + Co. KG.

ACCESSORIES



Whether you need storage systems, grinders, urethane rolls, hand tools or related supplies, we offer a wide range of solutions to help you be more productive, organized and efficient.



WT-STYLE PRESS BRAKE TOOLING

Precision Manufactured for Consistent Results.

WT Precision press brake tooling is precision manufactured to a tolerance of $\pm .0004"$ [$.01\text{mm}$] on all critical dimensions. Lengths of 19.69" [500mm] solid and sectionalized sets with various pieces can be mixed and matched for consistent bending quality throughout multiple jobs.

- Tools can be loaded by a single operator
- Easy to store – Cabinets available
- Sectionalized tools come in twelve pieces
- Sectionalized punches include two ear pieces (horns)
- Heat treat options include Nitrex® and laser hardening
- Nitrex® [HRC-70] is standard on dies

Standard Punch & Die Lengths

Solid	
200	7.874" [200mm]
500	19.685" [500mm]
Sectionalized	
X	41.339" [1050] All Sections
X1 19.685" [500mm]	.984" [25mm] Quantity 2
	1.181" [30mm]
	1.378" [35mm]
	1.575" [40mm]
	1.772" [45mm]
	3.937" [100mm] Left Ear
	3.937" [100mm]
	3.937" [100mm] Right Ear
X2 21.654" [550mm]	1.969" [50mm]
	7.874" [200mm]
	11.811" [300mm]

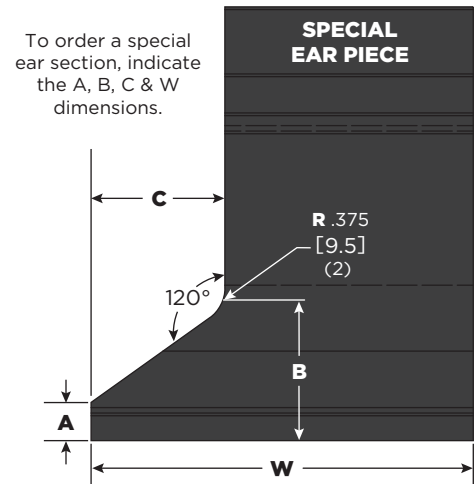
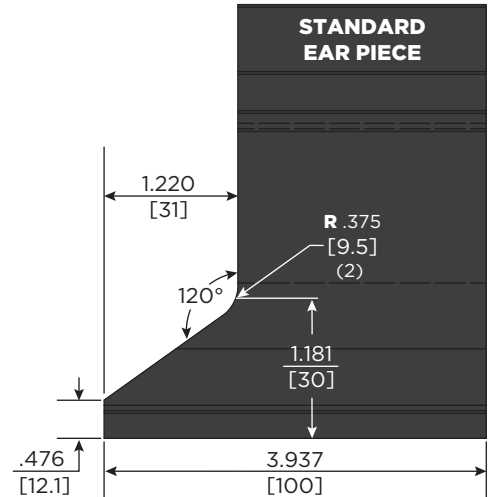

STANDARD PUNCH & DIE SECTION LENGTHS

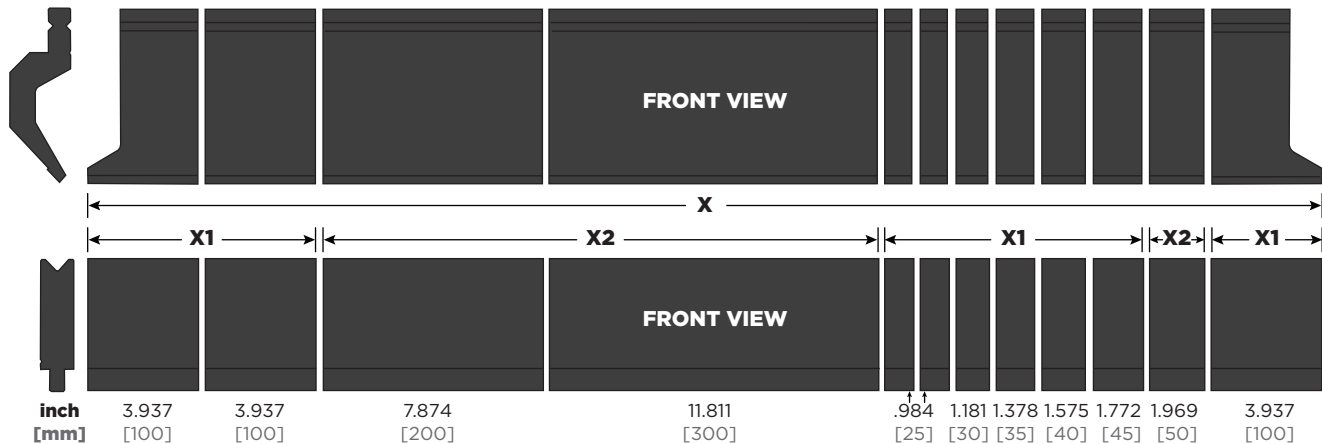

PUSH-BUTTON TECHNOLOGY

Load and unload tools instantly with Wilson Tool International's unique click-in feature. Wilson Tool's push-button technology eliminates the need for special clamps, holders or dedicated upper beams, significantly reducing costly downtime.

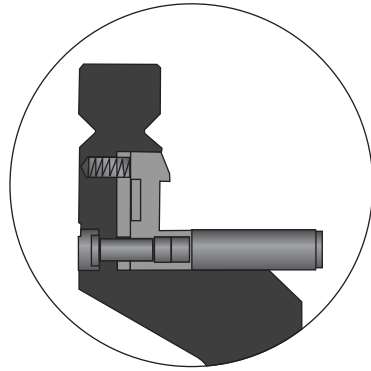

BUTTON

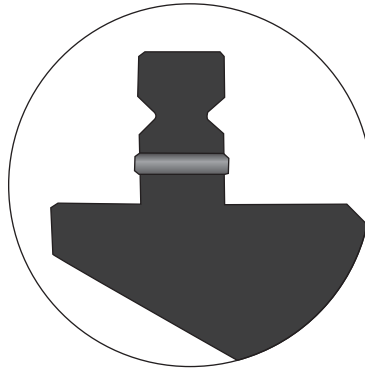

PIN

Profile	500	X1	X2
120mm / 140mm			
600 Series	P	B4	B4
601 Series	B2	B2	B2
602 Series	B1	B1	B1
603 Series	P	B3	B3
604 Series	B1	B1	B1
605 Series	P	B5	P/B5
220mm / 240mm			
610 Series	P	B5	P/B5
611 Series	P	B3	P/B3
612 Series	P	B3	P/B3
613 Series	P	B3	P/B3
614 Series	P	B3	P/B3
163mm			
92080060	P	B4	P/B4
92086010	P	B2	B2
92180010	P	B2	B2
92228010	B1	B1	B1
92460030	P	B1	B1
200mm			
93080060	P	B4	B4
93086010	P	B4	B4
93180010	P	B2	B2
93228010	P	B1	B1
93460030	P	B1	B1

Code	Part No.	Description	Price
BUTTON EXTENSION [Vertically load and unload]			
B1	980938	WT G3 safety button flush extension*	
B2	980939	WT G3 safety button extension 15mm*	
B3	980940	WT G3 safety button extension 25mm*	
B4	980941	WT G3 safety button extension 39mm*	
B5	980942	WT G3 Safety button extension 50mm*	
		*Plus one of each of the following components:	
	980157	Spring Ø .180" x .022" x .560" long	
	50079	Push button logo plug, small	
	980130	WT safety tang	
	980943	WT safety tang shoulder bolt	
PIN [Slide in, slide out]			
P	43741	Dowel pin Ø 5 mm x .25mm long	

120mm FAMILY PUNCHES

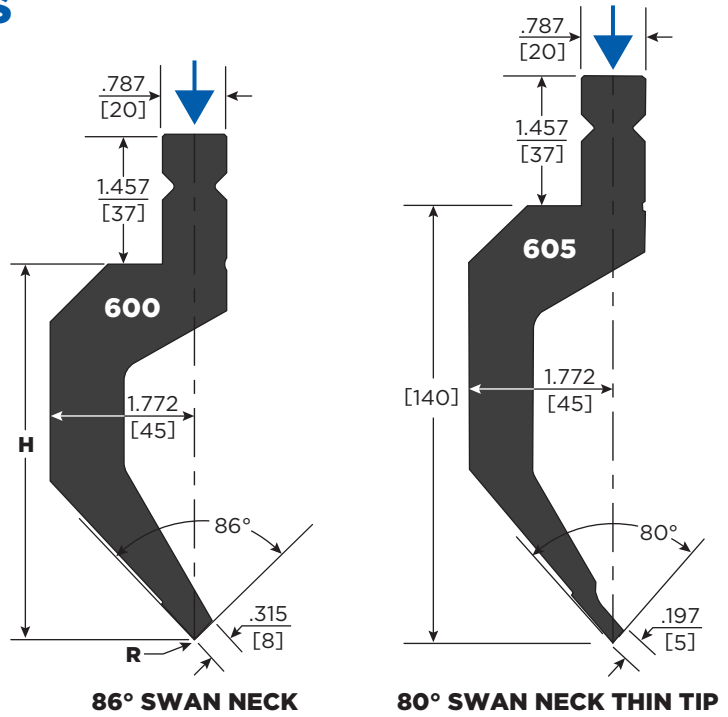

M Made To Order

↓ Indicates how tonnage is applied to punches

Part No.	Ref. No.	R Tip Radius inch [mm]	H Height inch [mm]	kN/m	Max. Ton feet [meter]	200 7.874" [200mm]	500 19.685" [500mm]	Sectionalized		
								X 41.339" [1050mm]	X1 19.685" [500mm]	X2 21.654" [550mm]
SERIES 600 — 86° SWAN NECK										
60086010		.039 [1.0]	4.724 [120.0]							
60086005	M	.020 [0.5]	4.717 [119.8]							
60086016	M	.063 [1.6]	4.693 [119.2]							
60086020	M	.079 [2.0]	4.693 [119.2]							
60086023	M	OW200k	.091 [2.3]	4.685 [119.0]	850	26 [87]				
60086025	M		.098 [2.5]	4.685 [119.0]						
60086030	M		.118 [3.0]	4.673 [118.7]						
60086032	M		.126 [3.2]	4.669 [118.6]						
60086040	M		.157 [4.0]	4.657 [118.3]						
Button Options:						B4	CS	B4	B4	B4
Approx. Gross Weight Unboxed:						13 lbs	32 lbs	63 lbs	28 lbs	35 lbs
SERIES 605 — 80° SWAN NECK THIN TIP										
60580005	OW280k	.020 [0.5]	5.512 [140]	400	12 [40]	—				
Button Options:						—	P	P/B5	B5	P/B5
Approx. Gross Weight Unboxed:						29 lbs	73 lbs	153 lbs	72 lbs	80 lbs

Tooling for special application available upon request.



120mm FAMILY PUNCHES

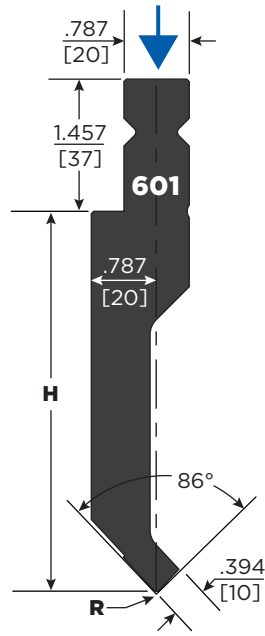

86° GOOSENECK

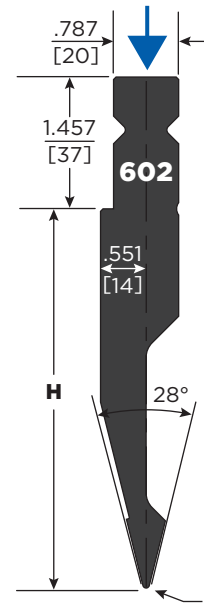

28° ACUTE w/RELIEF

M Made To Order

↓ Indicates how tonnage is applied to punches

Part No.	Ref. No.	R Tip Radius inch [mm]	H Height inch [mm]	kN/m	Max. Ton feet [meter]	500 19,685" [500mm]	Sectionalized			
							X 41,339" [1050mm]	X1 19,685" [500mm]	X2 21,654" [550mm]	
SERIES 601 — 86° GOOSENECK										
60186010		.039 [1.0]	4.724 [120.0]	900	28 [92]					
60186005	M	.020 [0.5]	4.717 [119.8]							
60186016	M	.063 [1.6]	4.701 [119.4]							
60186020	M	.079 [2.0]	4.693 [119.2]							
60186023	M	.091 [2.3]	4.685 [119.0]							
60186025	M	.098 [2.5]	4.685 [119.0]							
60186030	M	.118 [3.0]	4.677 [118.8]							
60186032	M	.126 [3.2]	4.669 [118.6]							
60186040	M	.157 [4.0]	4.654 [118.2]							
Button Options:							B2	B2	B2	B2
Approx. Gross Weight Unboxed:							27 lbs.	52 lbs.	23 lbs.	29 lbs.
SERIES 602 — 28° ACUTE w/RELIEF										
60228010		.039 [1.0]	4.724 [120.0]	1000	31 [102]					
60228005	M	.020 [0.5]	4.717 [119.8]							
60228016	M	.063 [1.6]	4.614 [117.2]							
60228020	M	.079 [2.0]	4.567 [116.0]							
60228023	M	.091 [2.3]	4.531 [115.1]							
60228025	M	.098 [2.5]	4.504 [114.4]							
60228030	M	.118 [3.0]	4.441 [112.8]							
60228032	M	.126 [3.2]	4.437 [112.7]							
60228040	M	.157 [4.0]	4.323 [109.8]							
Button Options:							B1	B1	B1	B1
Approx. Gross Weight Unboxed:							21 lbs.	45 lbs.	21 lbs.	24 lbs.

Tooling for special application available upon request.

120mm FAMILY PUNCHES

140mm FAMILY PUNCHES

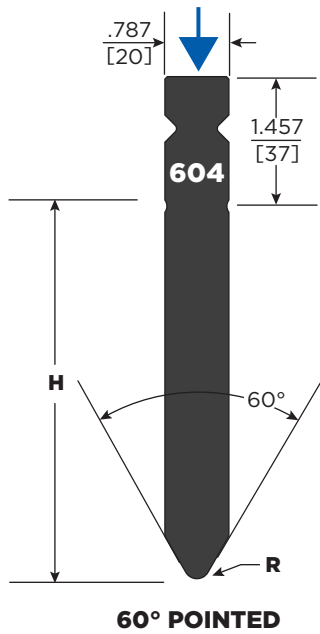

60° POINTED

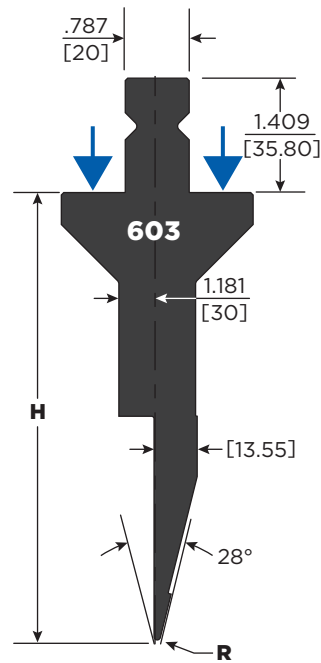

28° HEMMING

PUNCHES

M Made To Order

↓ Indicates how tonnage is applied to punches

Part No.	Ref. No.	R Tip Radius inch [mm]	H Height inch [mm]	kN/m	Max. Ton feet [meter]	200 7.874" [200mm]	500 19.685" [500mm]	Sectionalized		
								X 41.339" [1050mm]	X1 19.685" [500mm]	X2 21.654" [550mm]
SERIES 604 — 60° POINTED										
60460040		.157 [4.0]	4.724 [120.0]	1600	49 [163]	—				
60460020	M	.079 [2.0]	4.717 [119.8]							
60460025	M	.098 [2.5]	4.717 [119.8]							
60460030	M	.118 [3.0]	4.717 [119.8]							
60460047	M	.185 [4.7]	4.689 [119.1]							
60460050	M	.197 [5.0]	4.677 [118.8]							
60460060	M	.236 [6.0]	4.630 [117.6]							
Button Options:						—	B1	B1	B1	B1
Approx. Gross Weight Unboxed:						—	26 lbs.	54 lbs.	26 lbs.	28 lbs.
SERIES 603 — 28° HEMMING										
60328010		.039 [1.0]	5.512 [140]	650	20 [66]					
60328005	M	.020 [0.5]	5.504 [139.8]							
Button Options:						B3	CS	B3	B3	B3
Approx. Gross Weight Unboxed:						13 lbs.	32 lbs.	67 lbs.	32 lbs.	35 lbs.

Tooling for special application available upon request.



163mm FAMILY PUNCHES

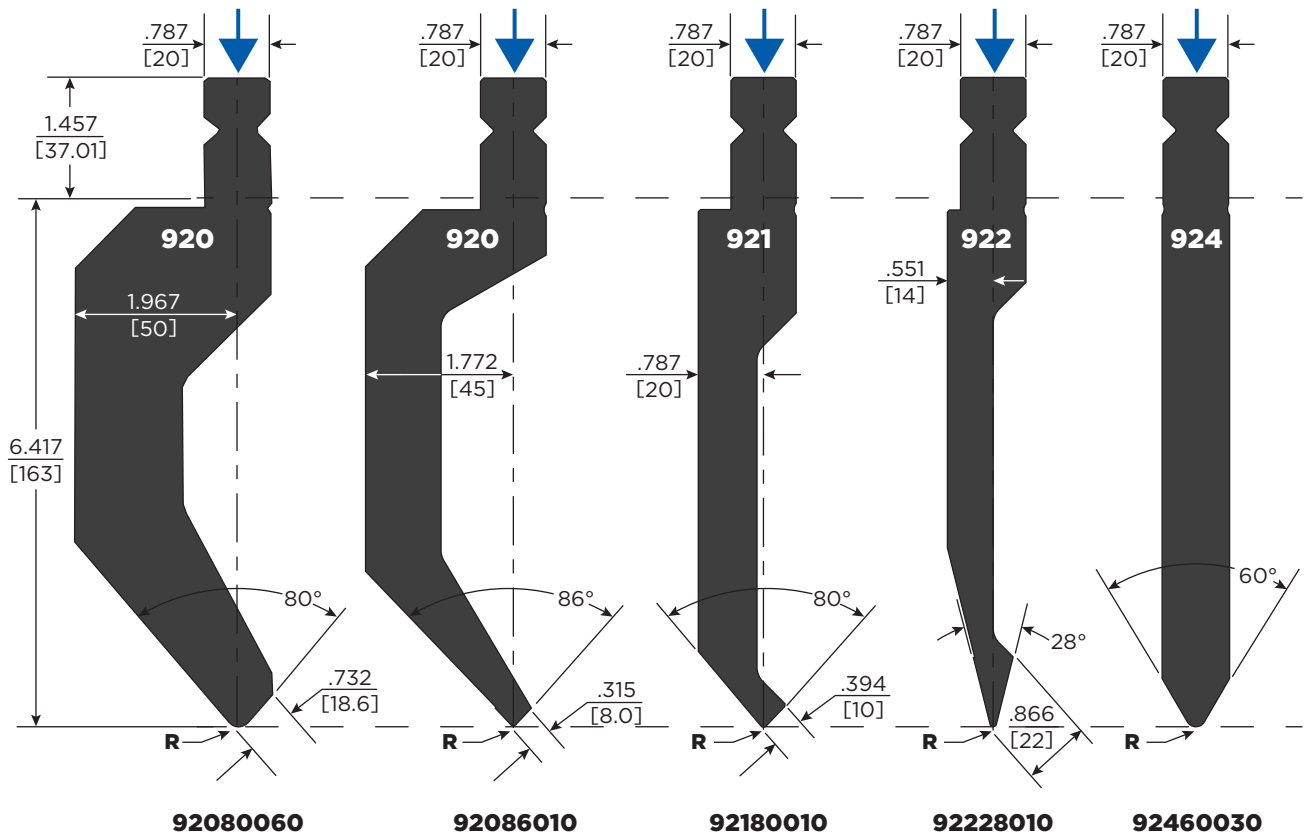

M Made To Order

↓ Indicates how tonnage is applied to punches

Part No. [Ref. No.]	H Height inch [mm]	R Tip Radius inch [mm]	Angle	kN/m	Max. Ton feet [meter]	Sectionalized					
						200 7.874" [200mm]	500 19.685" [500mm]	X 41.339" [1050mm]	X1 19.685" [500mm]	X2 21.654" [550mm]	
92080060 [BIU-025]	6.417 [163.0]	.236 [6]	80	1270	39 [130]	B4	P	P/B4	B4	P/B4	
Approx. Gross Weight Unboxed:						23 lbs.	58 lbs.	122 lbs.	58 lbs.	64 lbs.	
92086010 [BIU-023]		.039 [1]	86	640	20 [65]	B2	P	B2	B2	B2	
Approx. Gross Weight Unboxed:						16 lbs.	41 lbs.	86 lbs.	41 lbs.	45 lbs.	
92180010 [BIU-022]		M	.039 [1]	80	780	24 [80]	B2	P	B2	B2	B2
Approx. Gross Weight Unboxed:						14 lbs.	34 lbs.	71 lbs.	34 lbs.	37 lbs.	
92228010 [BIU-021]		.039 [1]	28	690	21 [70]	—	B1	B1	B1	B1	
Approx. Gross Weight Unboxed:						—	26 lbs.	54 lbs.	26 lbs.	28 lbs.	
92460030 [BIU-024]		.118 [3]	60	1570	48 [160]	B1	P	B1	B1	B1	
Approx. Gross Weight Unboxed:						14 lbs.	34 lbs.	71 lbs.	34 lbs.	37 lbs.	

Button Options shown in bold blue above

200mm FAMILY PUNCHES

PUNCHES

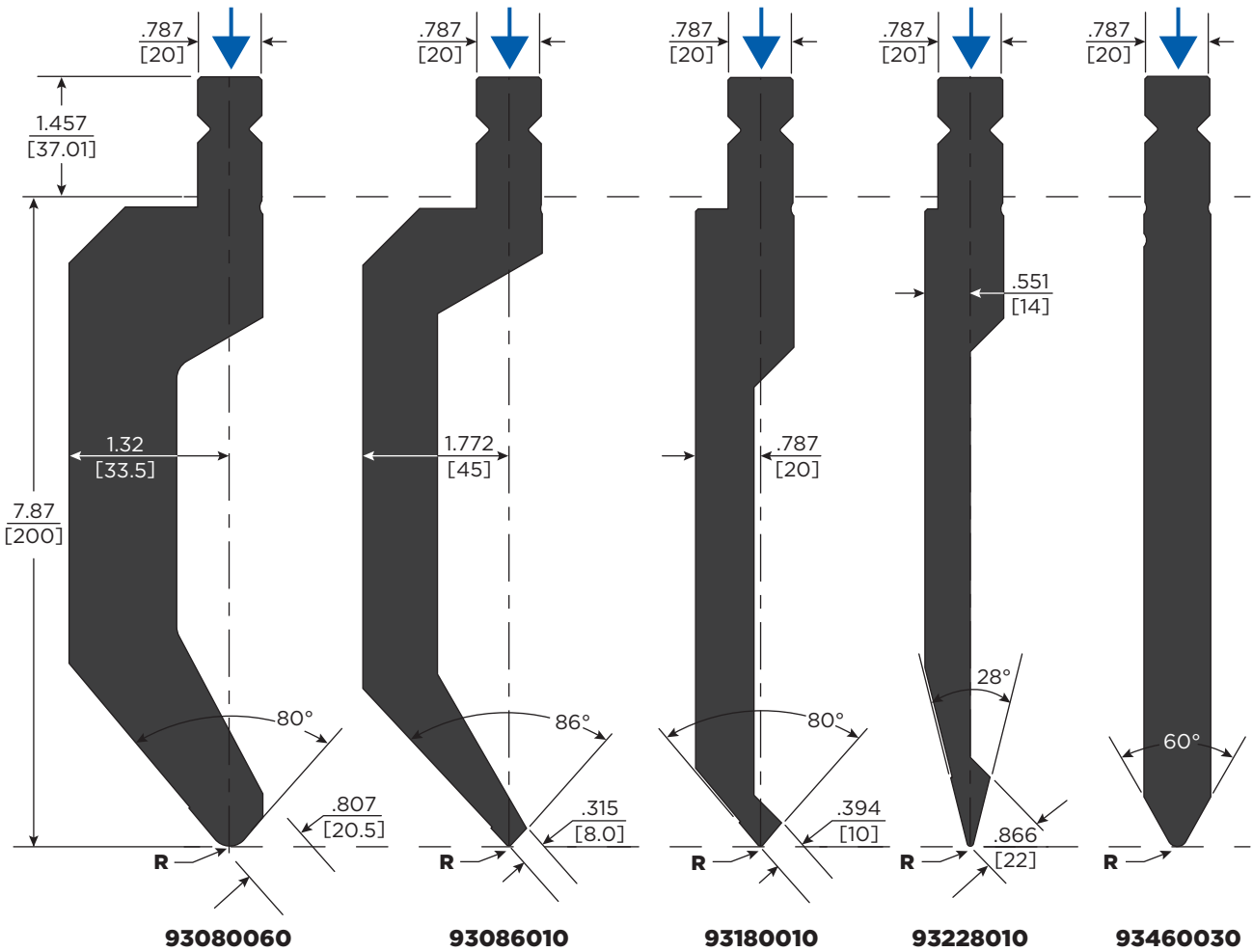

M Made To Order

↓ Indicates how tonnage is applied to punches

Part No. [Ref. No.]	H Height inch [mm]	R Tip Radius inch [mm]	Angle	kN/m	Max. Ton feet [meter]	Sectionalized					
						200 7.874" [200mm]	500 19.685" [500mm]	X 41.339" [1050mm]	X1 19.685" [500mm]	X2 21.654" [550mm]	
93080060 [BIU-235]	7.874 [200]	.236 [6]	80	1430	44 [130]	B4	P	B4	B4	B4	
Approx. Gross Weight Unboxed:						28 lbs.	70 lbs.	139 lbs.	62 lbs.	77 lbs.	
93086010 [BIU-033]		M	.039 [1]	86	490	15 [50]	B4	P	B4	B4	B4
Approx. Gross Weight Unboxed:						19 lbs.	48 lbs.	101 lbs.	48 lbs.	53 lbs.	
93180010 [BIU-032]		M	.039 [1]	80	780	24 [80]	B2	P	B2	B2	B2
Approx. Gross Weight Unboxed:						16 lbs.	40 lbs.	84 lbs.	40 lbs.	lbs. 44	
93228010 [BIU-031]	M	.039 [1]	28	590	18 [60]	B1	P	B1	B1	B1	
Approx. Gross Weight Unboxed:						12 lbs.	31 lbs.	65 lbs.	31 lbs.	34 lbs.	
93460030 [BIU-034]	M	.118 [3]	60	1570	48 [160]	B1	P	B1	B1	B1	
Approx. Gross Weight Unboxed:						16 lbs.	40 lbs.	84 lbs.	40 lbs.	44 lbs.	

Button Options shown in bold blue above



200mm FAMILY PUNCHES

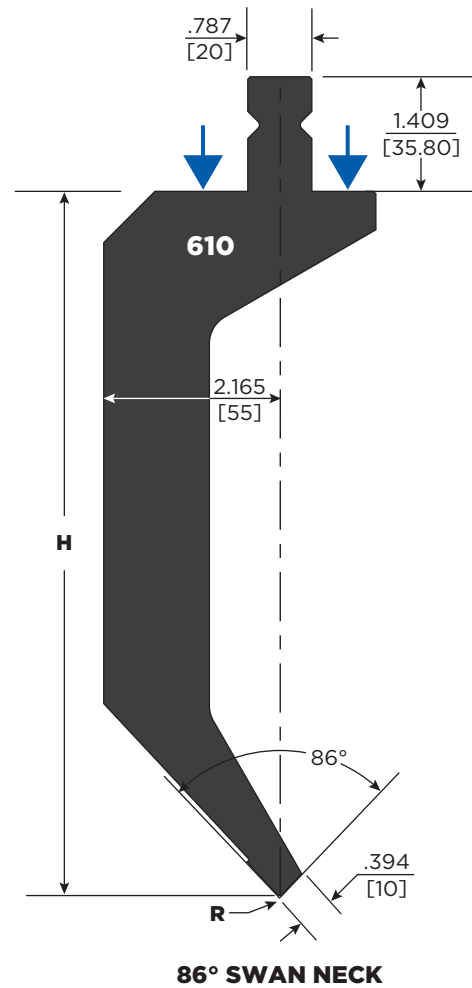

M Made To Order

↓ Indicates how tonnage is applied to punches

Part No.	Ref. No.	R Tip Radius inch [mm]	H Height inch [mm]	kN/m	Max. Ton feet [meter]	200 7.874" [200mm]	500 19.685" [500mm]	Sectionalized		
								X 41.339" [1050mm]	X1 19.685" [500mm]	X2 21.654" [550mm]
SERIES 610 — 86° SWAN NECK										
61086010		.039 [1.0]	8..661 [220.0]							
61086005	M	.020 [0.5]	8.654 [219.8]							
61086016	M	.063 [1.6]	8.630 [219.2]							
61086020	M	.079 [2.0]	8.630 [219.2]							
61086023	M	.091 [2.3]	8.622 [219.0]	850	26 [87]					
61086025	M	.098 [2.5]	8.610 [218.7]							
61086030	M	.118 [3.0]	8.602 [218.5]							
61086032	M	.126 [3.2]	8.602 [218.5]							
61086040	M	.157 [4.0]	8.594 [218.3]							
Button Options:						B5	P	P/B5	B5	P/B5
Approx. Gross Weight Unboxed:						29 lbs.	73 lbs.	153 lbs.	73 lbs.	80 lbs.

Tooling for special application available upon request.

220mm FAMILY PUNCHES

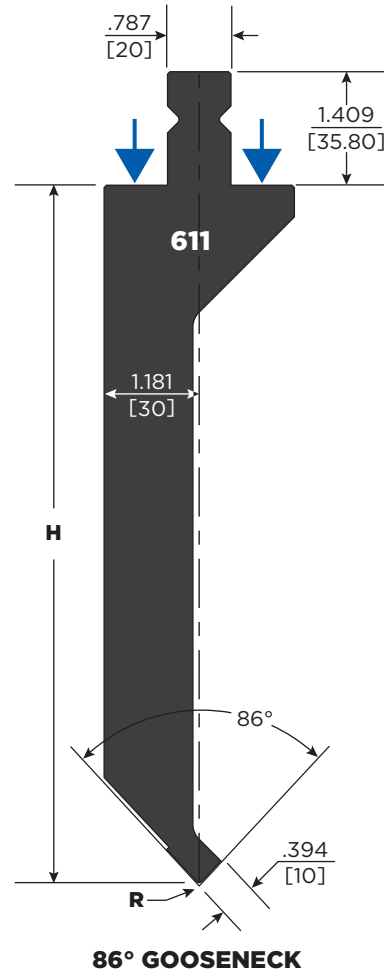

PUNCHES

M Made To Order

↓ Indicates how tonnage is applied to punches

Part No.	Ref. No.	R Tip Radius inch [mm]	H Height inch [mm]	kN/m	Max. Ton feet [meter]	200 7.874" [200mm]	500 19.685" [500mm]	Sectionalized		
								X 41.339" [1050mm]	X1 19.685" [500mm]	X2 21.654" [550mm]
SERIES 611 — 86° GOOSENECK										
61186010		.039 [1.0]	8.661 [220.0]							
61186005	M	.020 [0.5]	8.654 [219.8]							
61186016	M	.063 [1.6]	8.638 [219.4]							
61186020	M	.079 [2.0]	8.630 [219.2]							
61186023	M	.091 [2.3]	8.622 [219.0]	900	28 [92]					
61186025	M	.098 [2.5]	8.610 [218.7]							
61186030	M	.118 [3.0]	8.614 [218.8]							
61186032	M	.126 [3.2]	8.606 [218.6]							
61186040	M	.157 [4.0]	8.594 [218.3]							
Button Options:						B3	P	P/B3	B3	P/B3
Approx. Gross Weight Unboxed:						25 lbs.	62 lbs.	131 lbs.	62 lbs.	69 lbs.

Tooling for special application available upon request.



220mm FAMILY PUNCHES

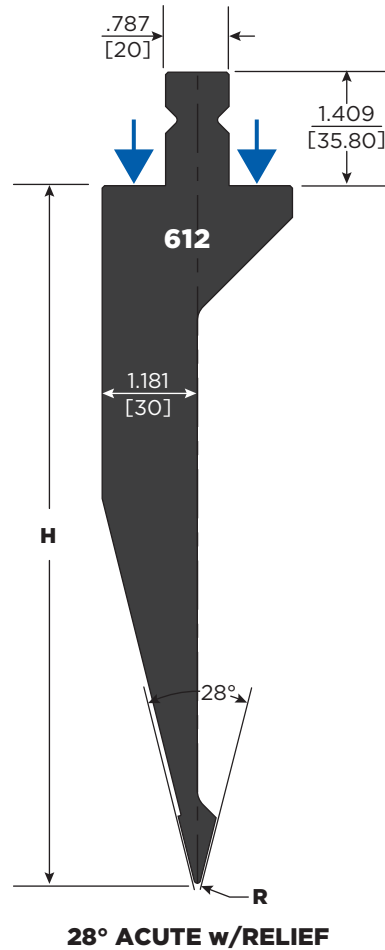

M Made To Order

↓ Indicates how tonnage is applied to punches

Part No.	Ref. No.	R Tip Radius inch [mm]	H Height inch [mm]	kN/m	Max. Ton feet [meter]	Sectionalized				
						200 7.874" [200mm]	500 19.685" [500mm]	X 41.339" [1050mm]	X1 19.685" [500mm]	X2 21.654" [550mm]
SERIES 612 — 28° ACUTE WITH RELIEF										
61228010		.039 [1.0]	8.661 [220.0]							
61228005	M	.020 [0.5]	8.654 [219.8]							
61228016	M	.063 [1.6]	8.575 [217.8]							
61228020	M	.079 [2.0]	8.504 [216.0]							
61228023	M	.091 [2.3]	8.488 [215.6]	1000	31 [102]					
61228025	M	.098 [2.5]	8.425 [214.0]							
61228030	M	.118 [3.0]	8.378 [212.8]							
61228032	M	.126 [3.2]	8.374 [212.7]							
61228040	M	.157 [4.0]	8.260 [209.8]							
Button Options:						B3	P	P/B3	B3	P/B3
Approx. Gross Weight Unboxed:						22 lbs.	54 lbs.	114 lbs.	54 lbs.	60 lbs.

Tooling for special application available upon request.

220mm FAMILY PUNCHES

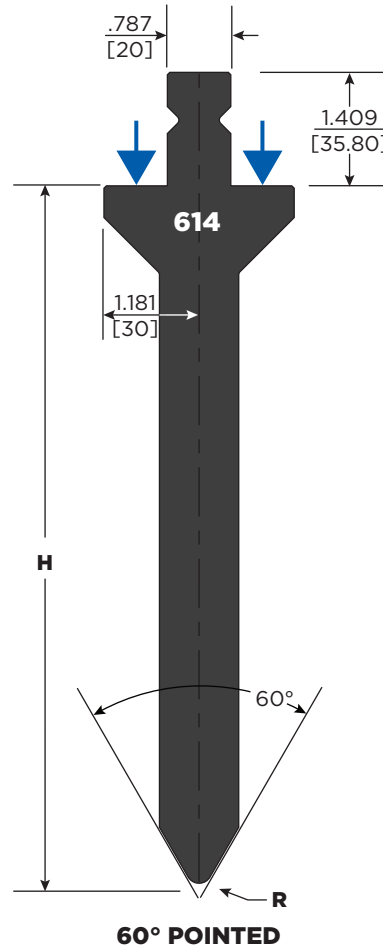

PUNCHES

M Made To Order

↓ Indicates how tonnage is applied to punches

Part No.	Ref. No.	R Tip Radius inch [mm]	H Height inch [mm]	kN/m	Max. Ton feet [meter]	200 7.874" [200mm]	500 19.685" [500mm]	Sectionalized			
								X 41.339" [1050mm]	X1 19.685" [500mm]	X2 21.654" [550mm]	
SERIES 614 — 60° POINTED											
61460040		.157 [4.0]	8.661 [220.0]								
61460020	M	.079 [2.0]	8.654 [219.8]								
61460025	M	.098 [2.5]	8.654 [219.8]								
61460030	M	.118 [3.0]	8.654 [219.8]	1600	49 [163]						
61460047	M	.185 [4.7]	8.622 [219.0]								
61460050	M	.197 [5.0]	8.606 [218.6]								
61460060	M	.236 [6.0]	8.567 [217.6]								
Button Options:						B3	P	P/B3	B3	P/B3	
Approx. Gross Weight Unboxed:						23 lbs.	57 lbs.	108 lbs.	51 lbs.	57 lbs.	

Tooling for special application available upon request.



240mm FAMILY PUNCHES

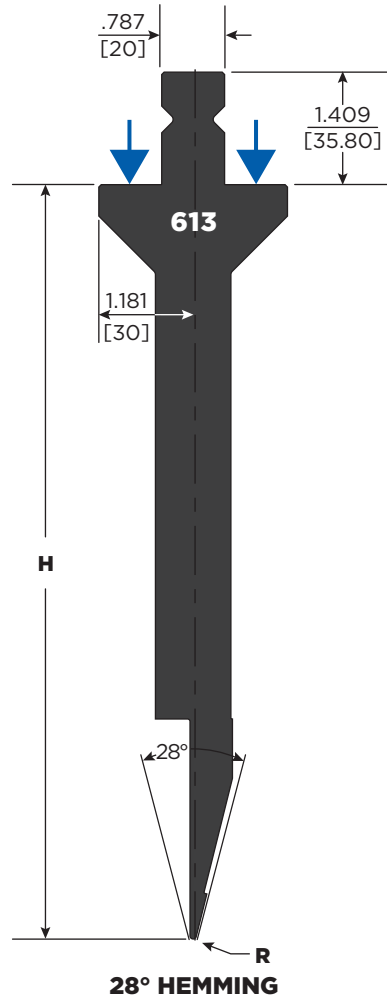

PUNCHES

M Made To Order

↓ Indicates how tonnage is applied to punches

Part No.	Ref. No.	R Tip Radius inch [mm]	H Height inch [mm]	kN/m	Max. Ton feet [meter]	Sectionalized				
						200 7.874" [200mm]	500 19.685" [500mm]	X 41.339" [1050mm]	X1 19.685" [500mm]	X2 21.654" [550mm]
SERIES 613 — 28° HEMMING										
61328010	OW210s	.039 [1.0]	9.449 [240.0]	650	20 [66]					
61328005		M	.020 [0.5]		9.441 [239.8]	—				
Button Options:						B3	P	P/B3	B3	P/B3
Approx. Gross Weight Unboxed:						21 lbs.	52 lbs.	103 lbs.	46 lbs.	57 lbs.

Tooling for special application available upon request.

HOW TO USE A BEND LIMIT GRAPH

Although a bend limit graph won't help with bend sequencing, it will help determine what punch profile is best for you. Visit our YouTube channel for a step-by-step video on using these graphs.

- The graphs are 1:1
- Your part can be laid on top of the catalog page
- Use inside dimensions — always account for material thickness

This application works.

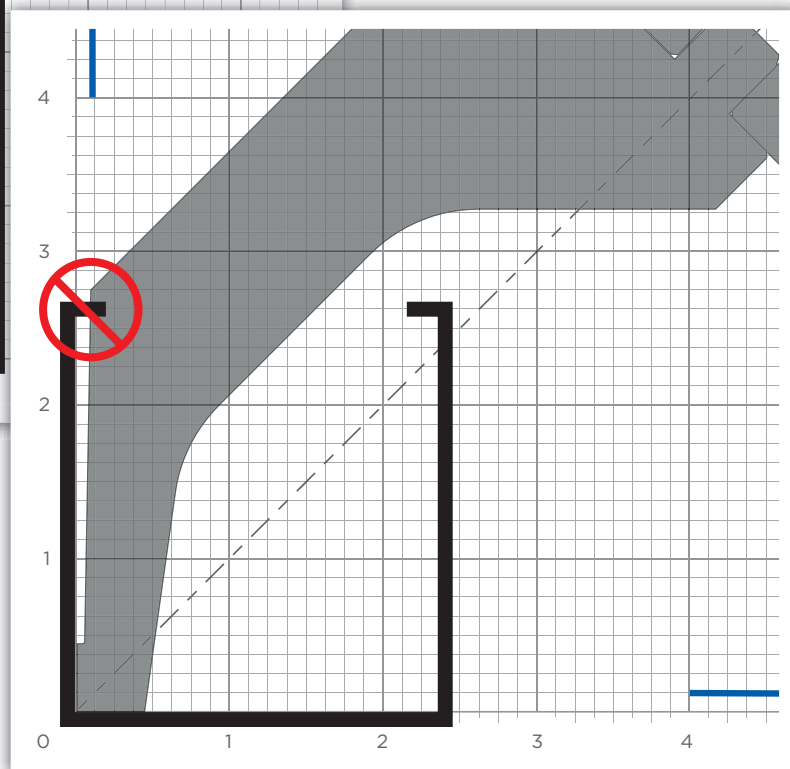
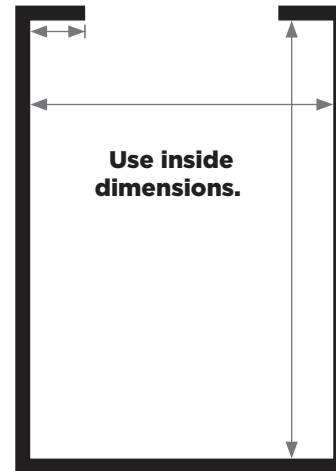
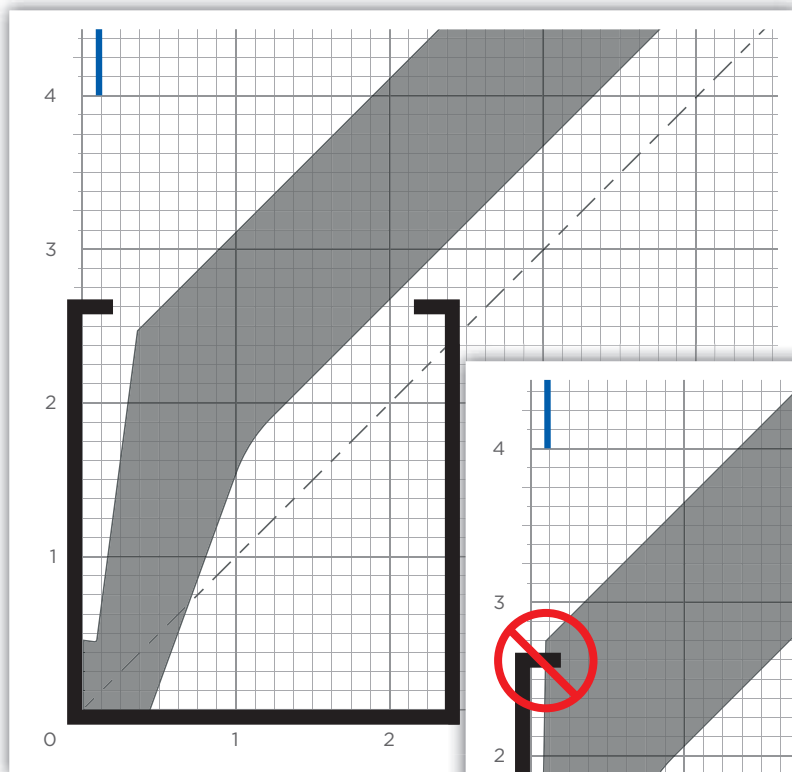

This application doesn't work.



Scan QR Code to
Watch the Video



600 – 86° SWAN NECK PUNCH

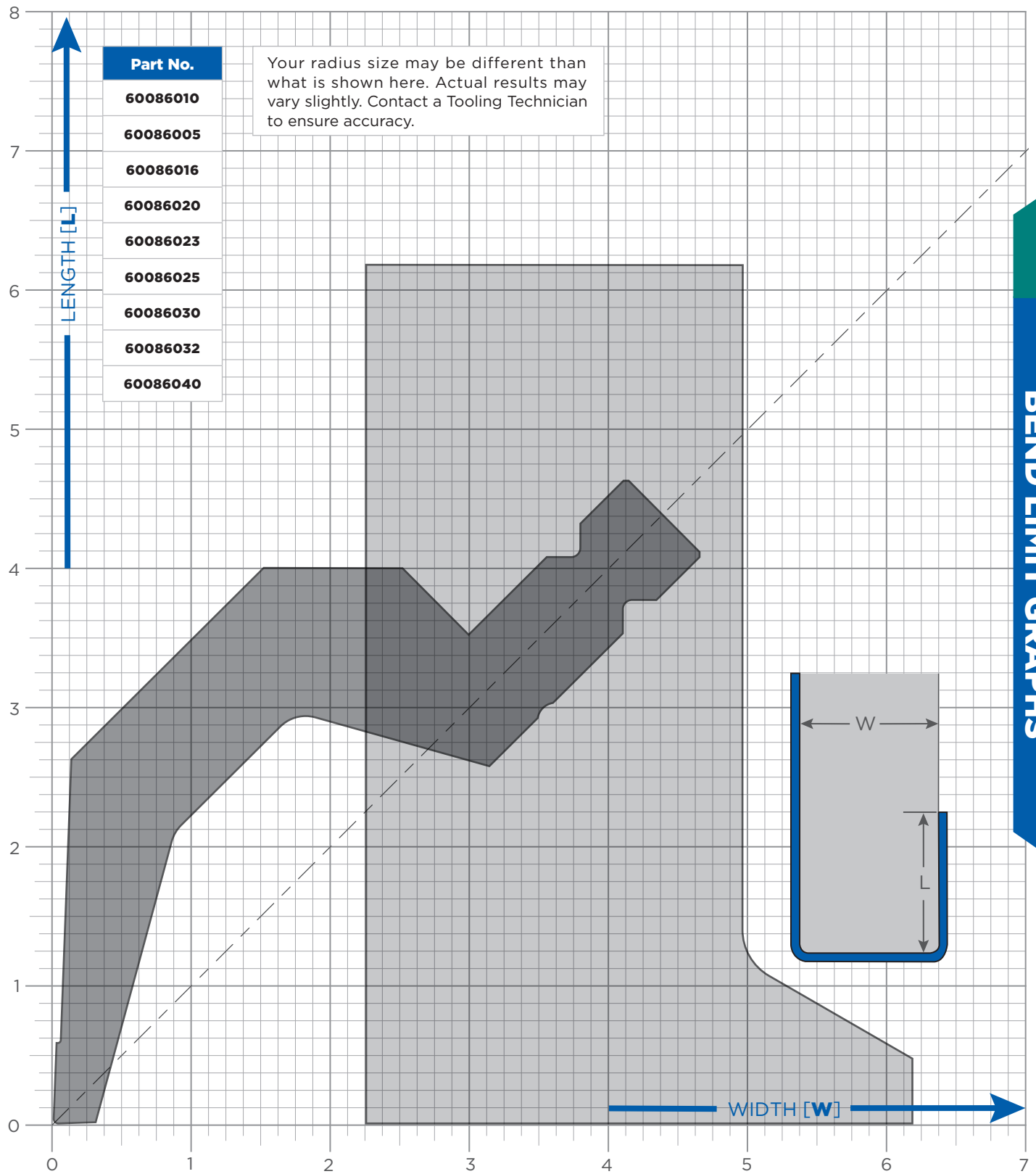

605 – 80° THIN TIP SWAN NECK PUNCH

BEND LIMIT GRAPHS

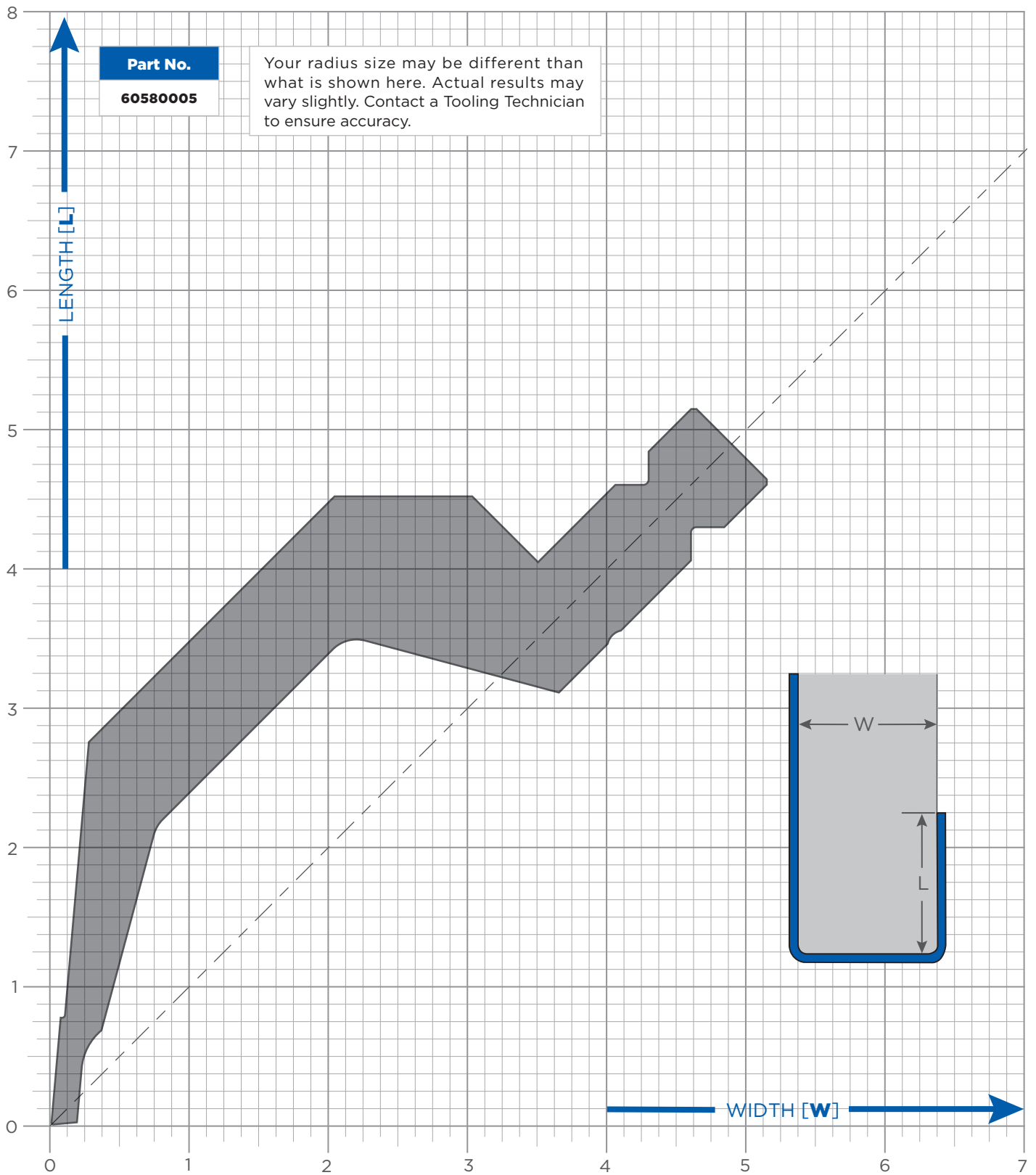

601 – 86° GOOSENECK PUNCH

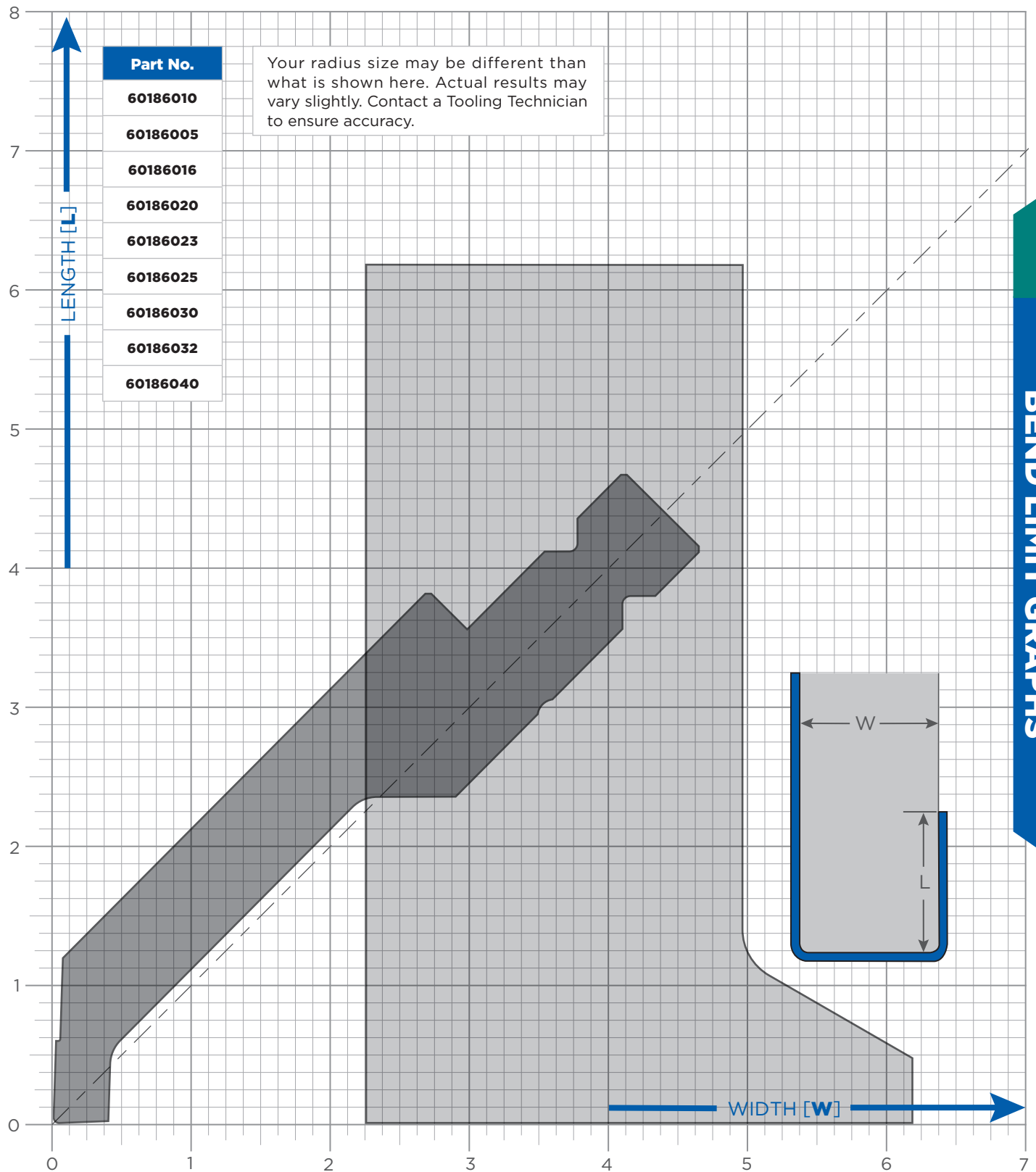

BEND LIMIT GRAPHS

602 – 28° ACUTE WITH RELIEF PUNCH

BEND LIMIT GRAPHS

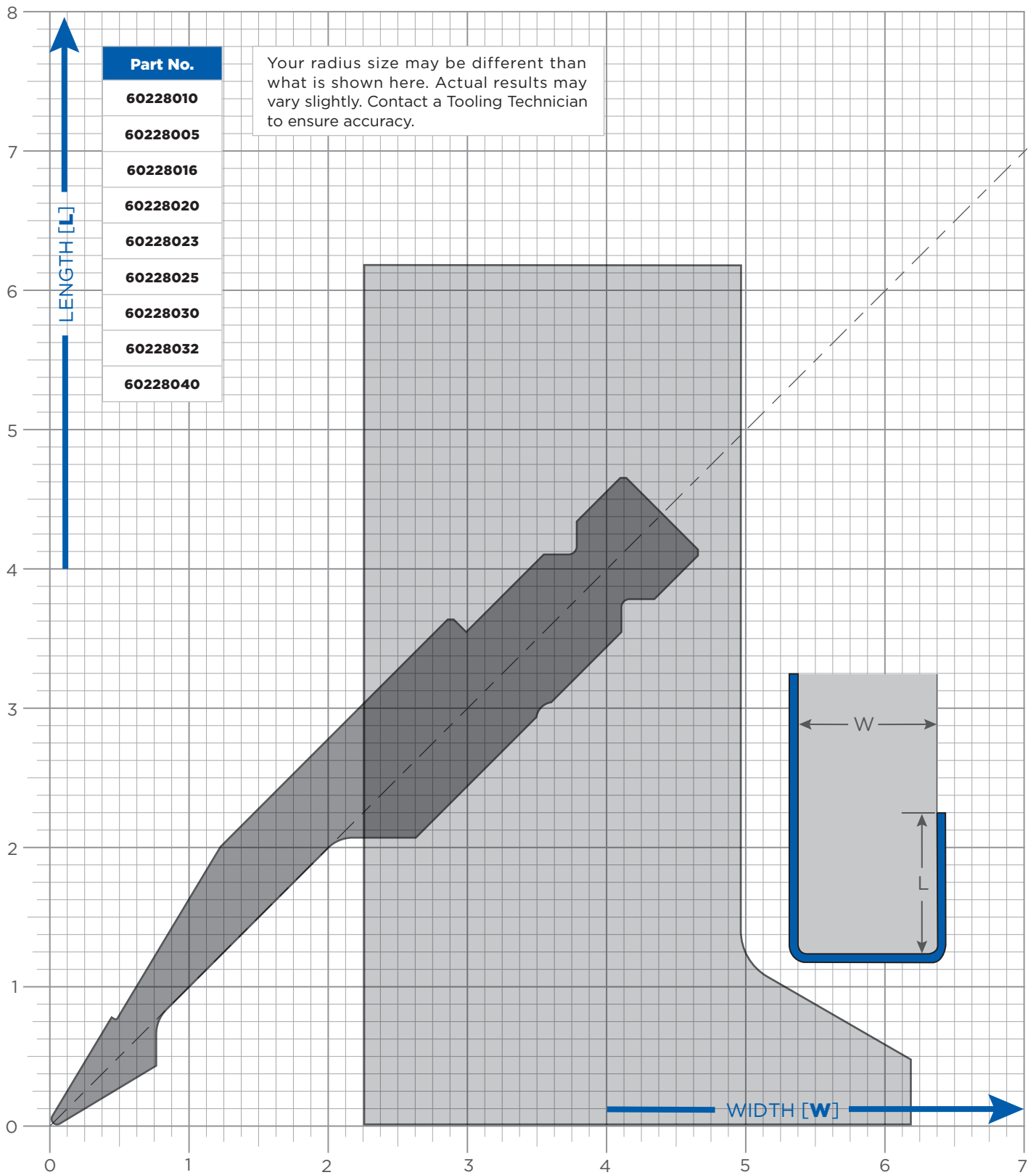

603 — 28° HEMMING PUNCH

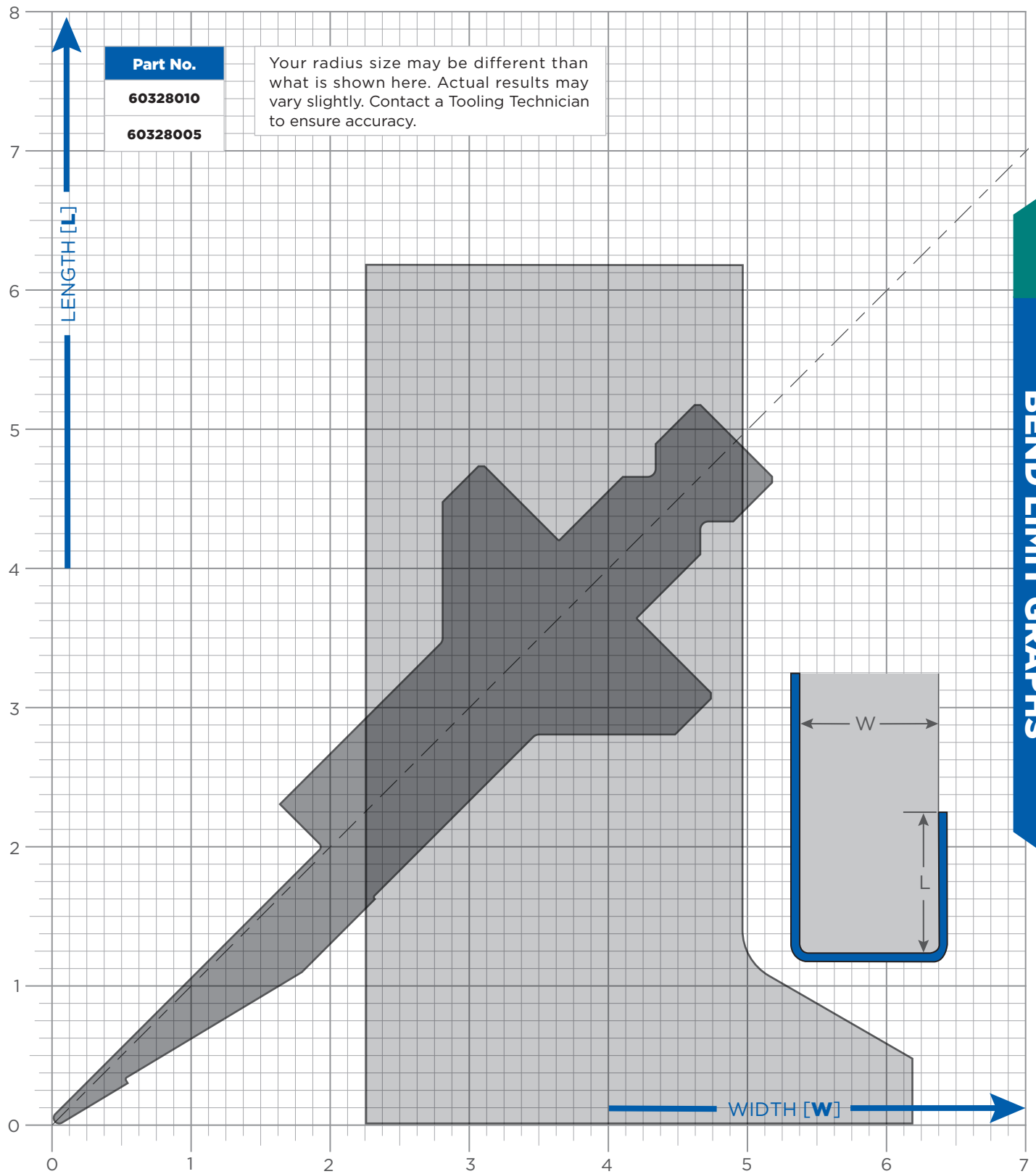

604 — 60° POINTED/BOTTOMING PUNCH

BEND LIMIT GRAPHS

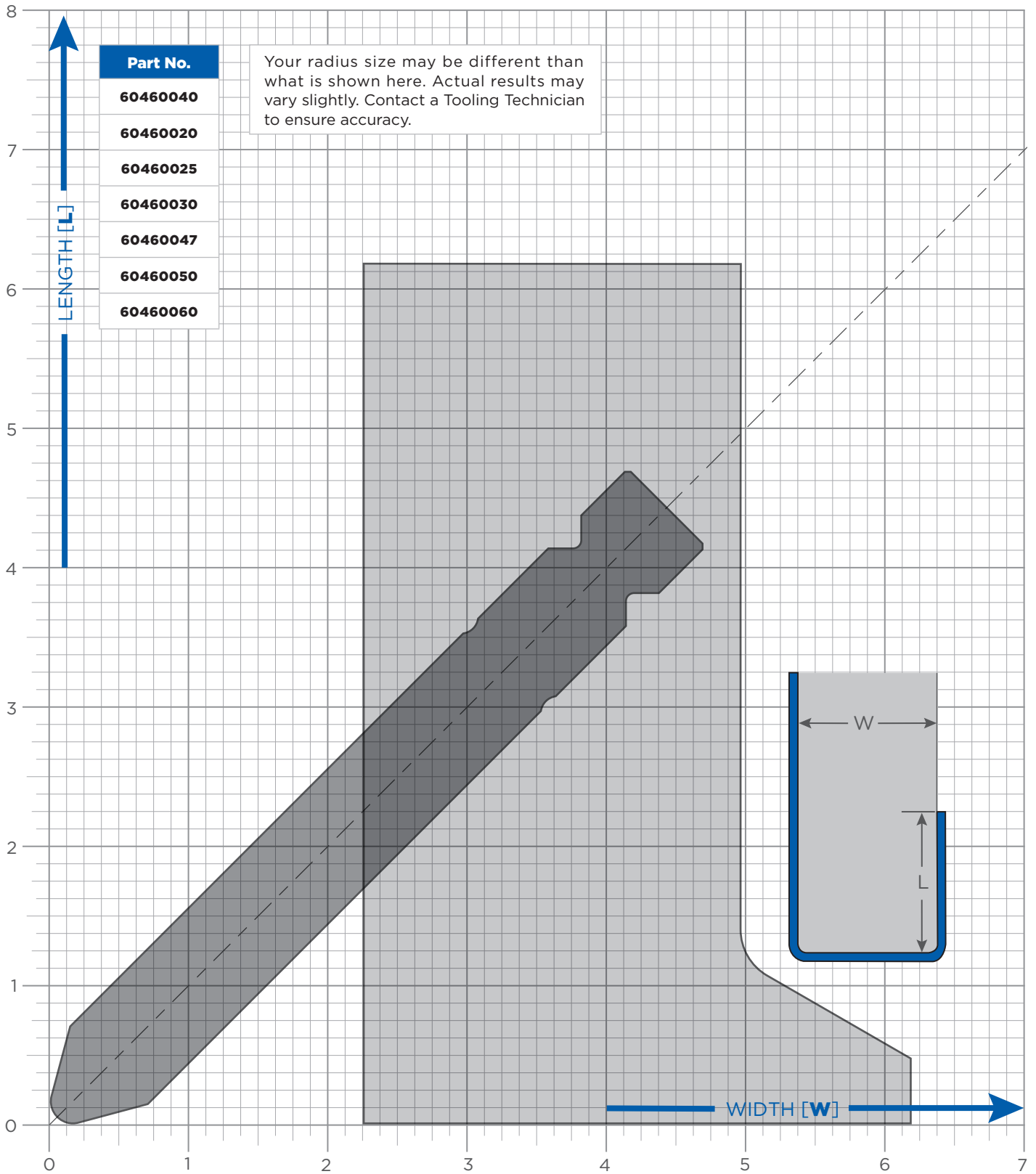

920 — 80° LARGE TIP SWAN NECK PUNCH

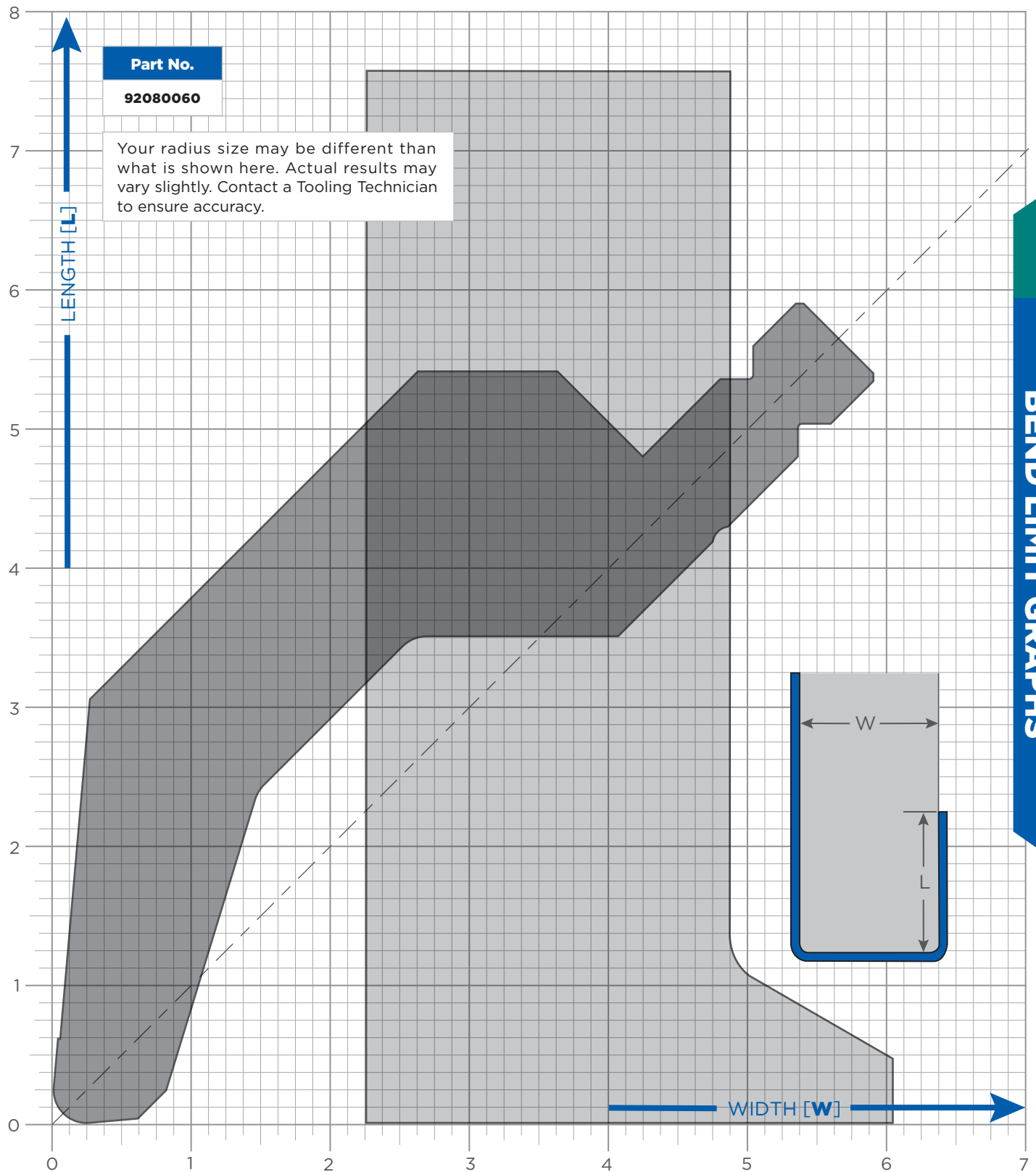

920 – 86° SWAN NECK PUNCH

BEND LIMIT GRAPHS

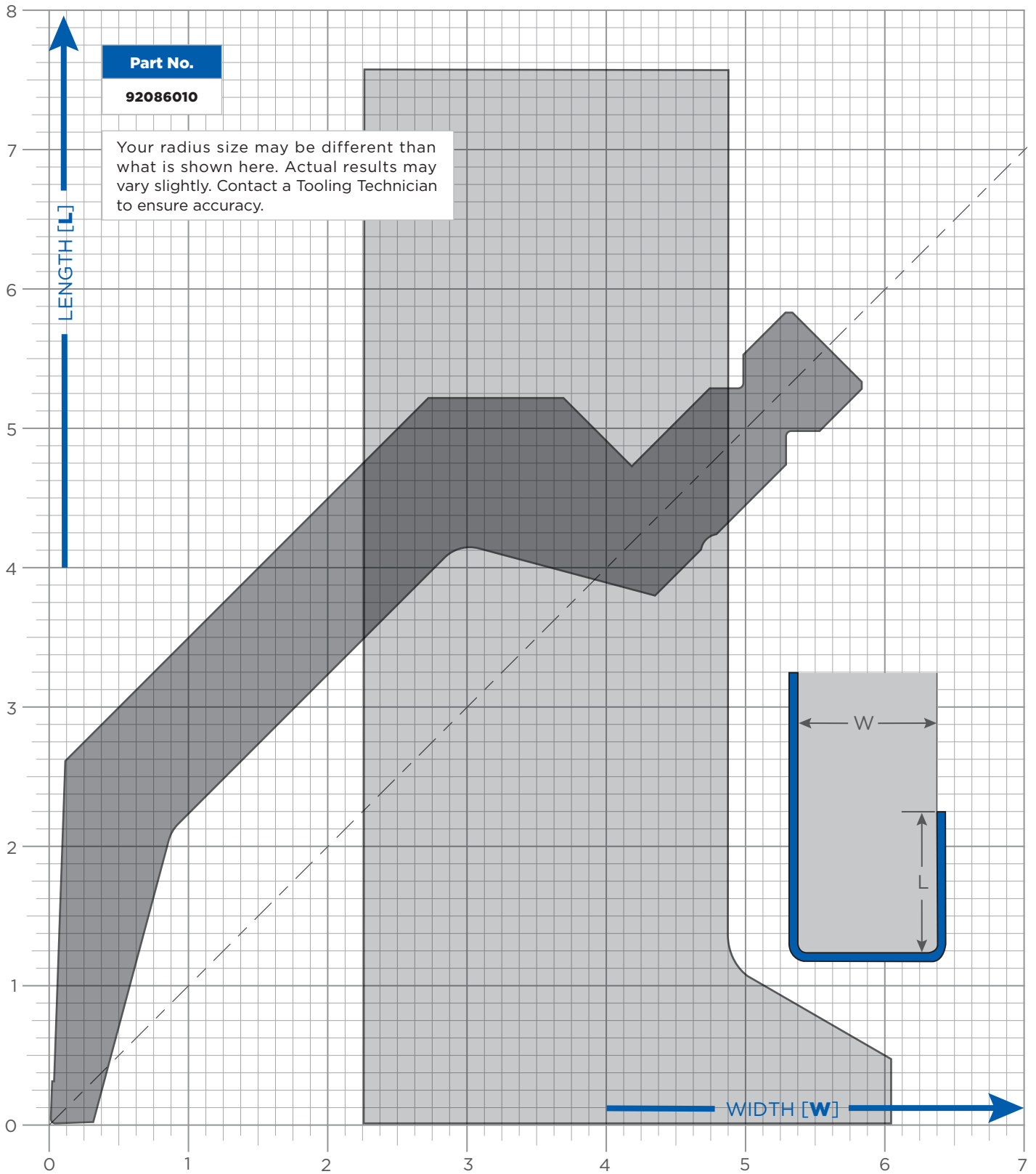

921 — 80° GOOSENECK PUNCH

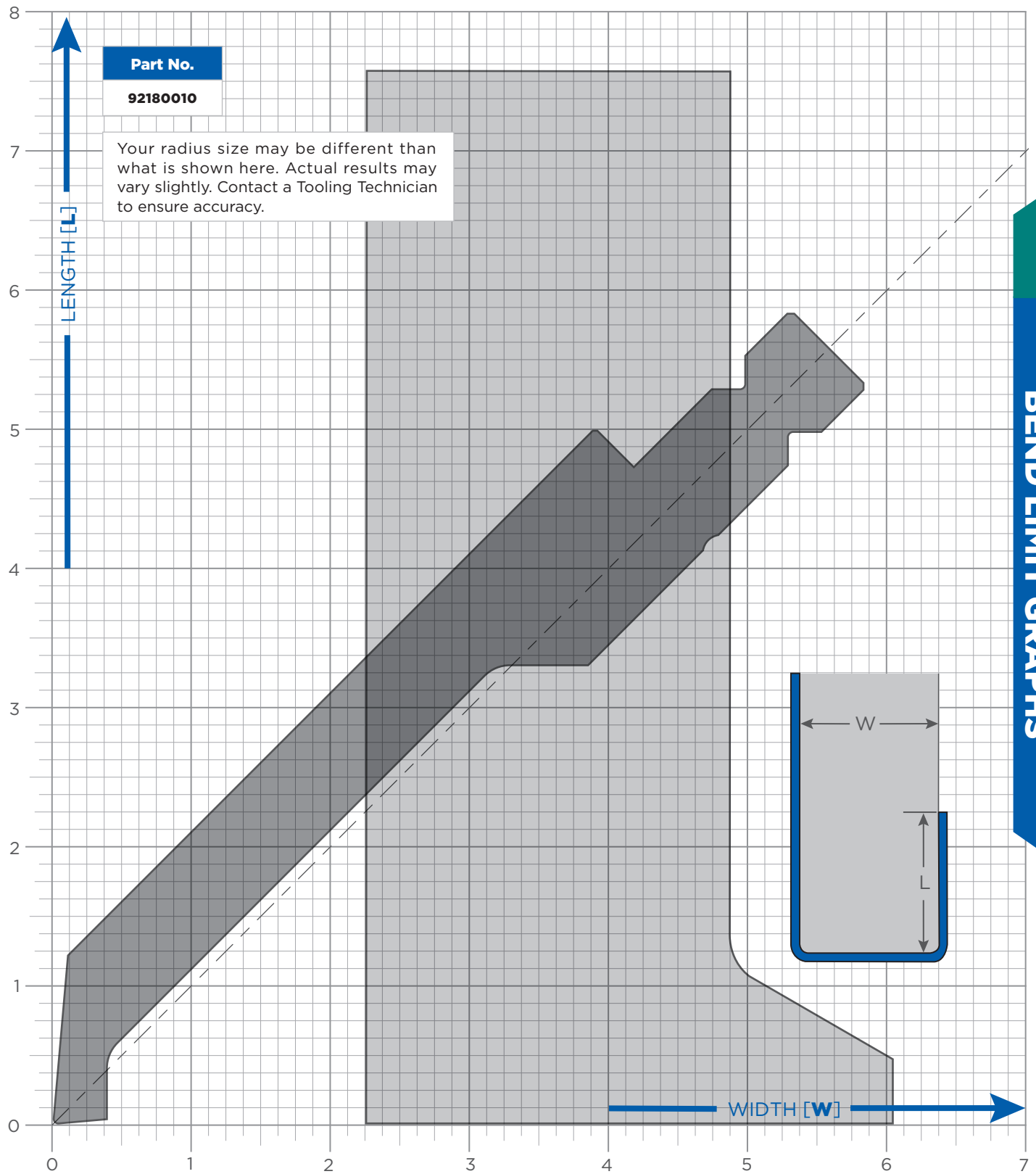

922 – 28° ACUTE PUNCH

BEND LIMIT GRAPHS

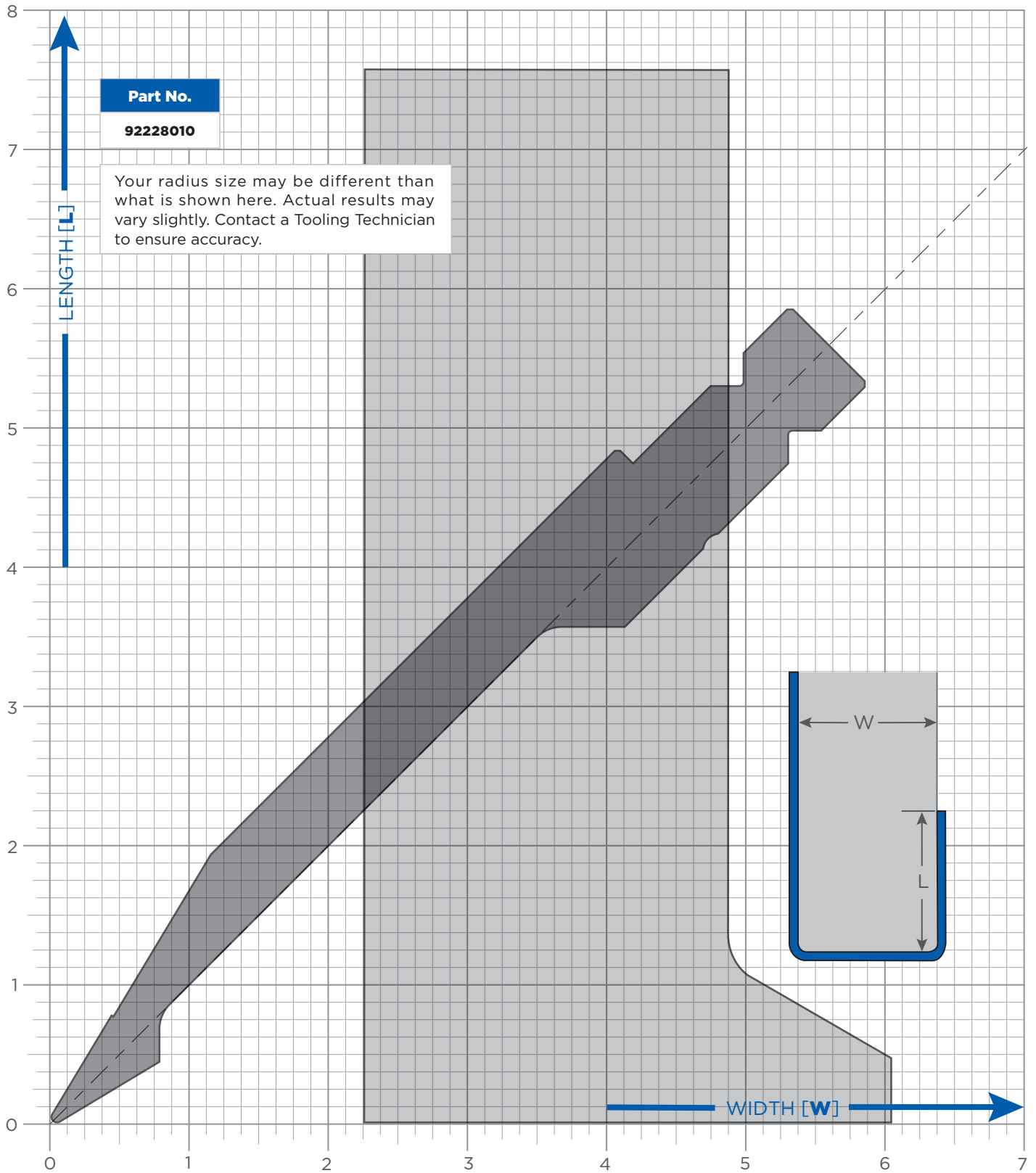

924 – 60° BLOCK PUNCH

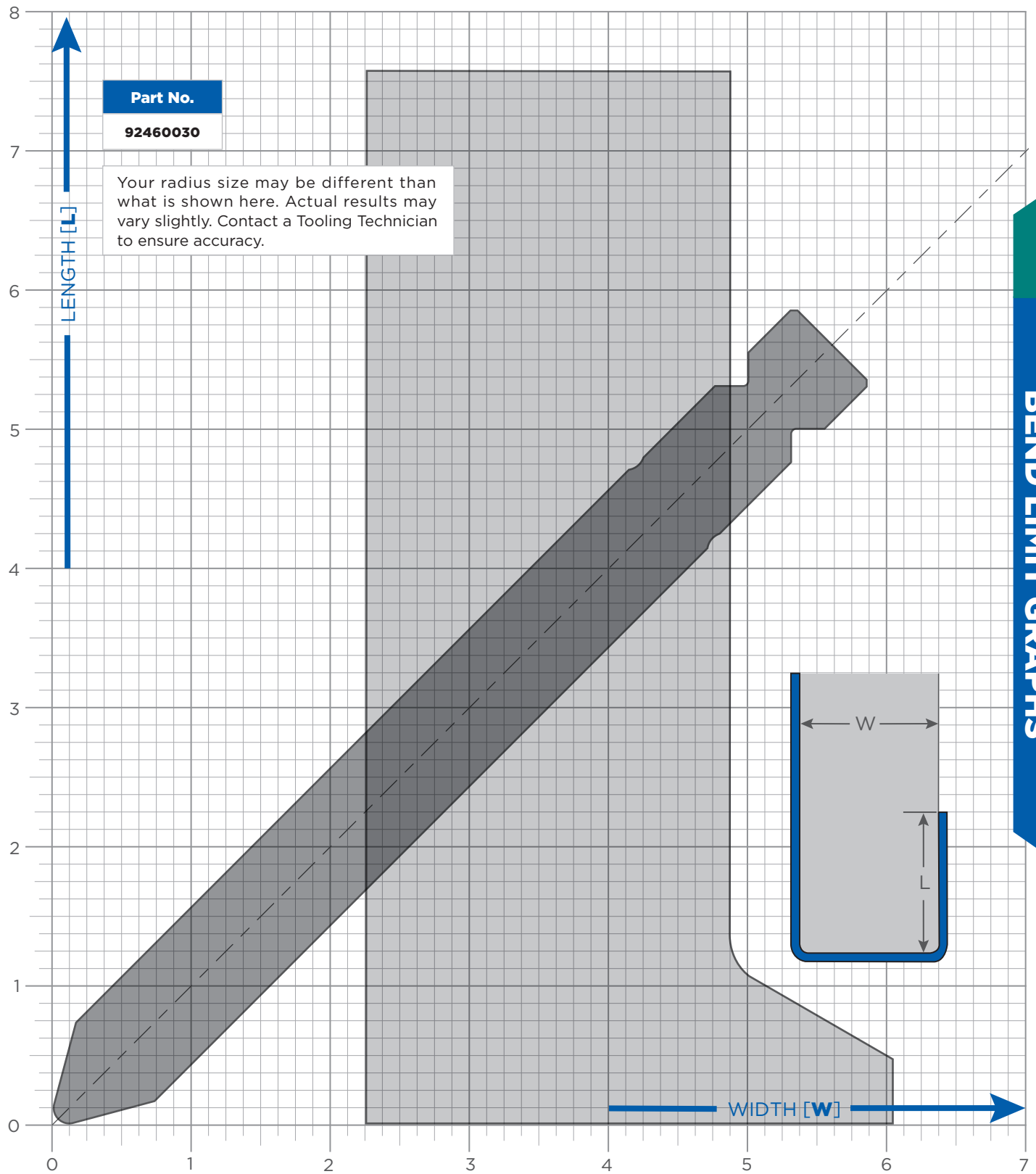

930 — 80° LARGE TIP SWAN NECK PUNCH

BEND LIMIT GRAPHS

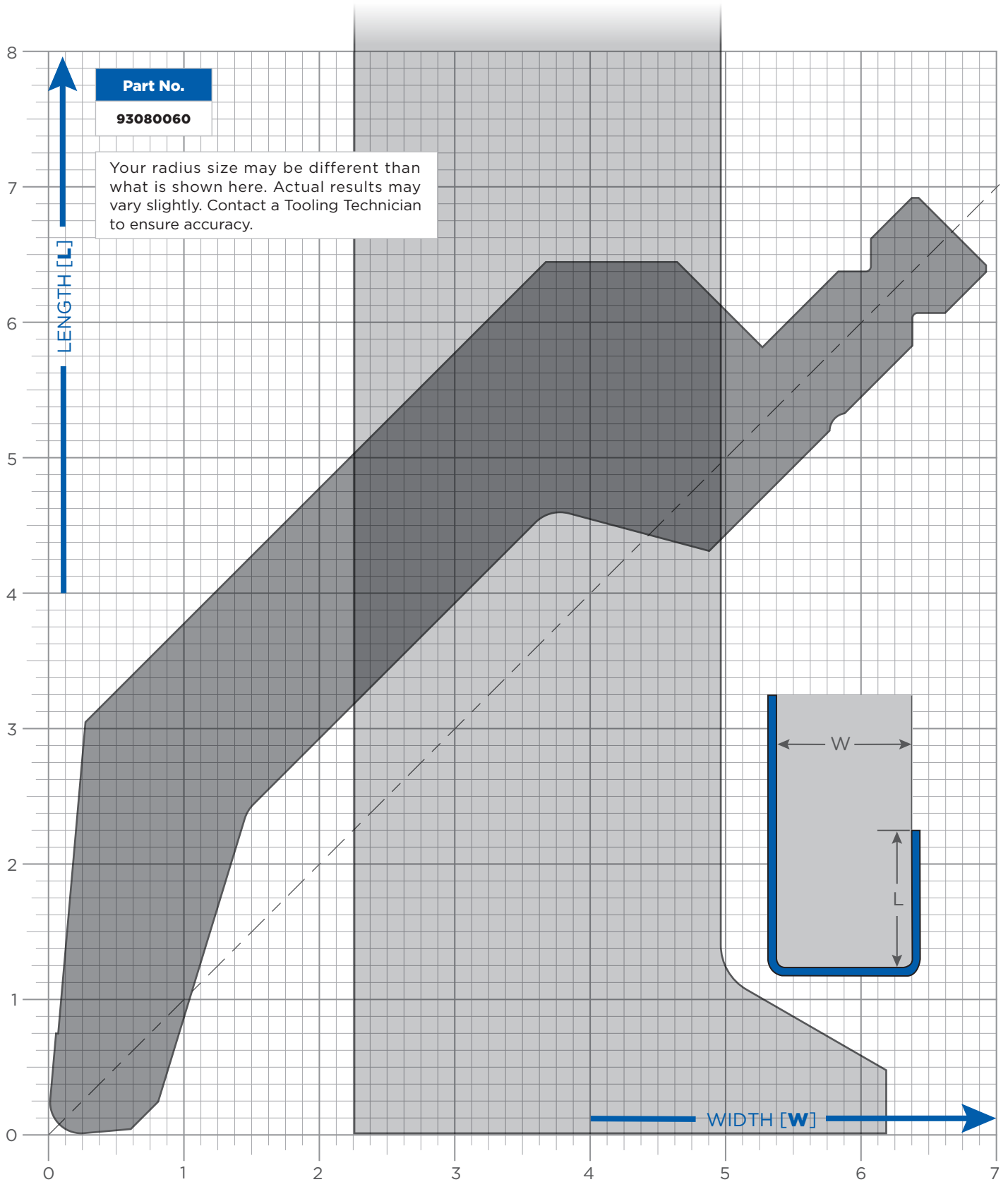

930 — 86° SWAN NECK PUNCH

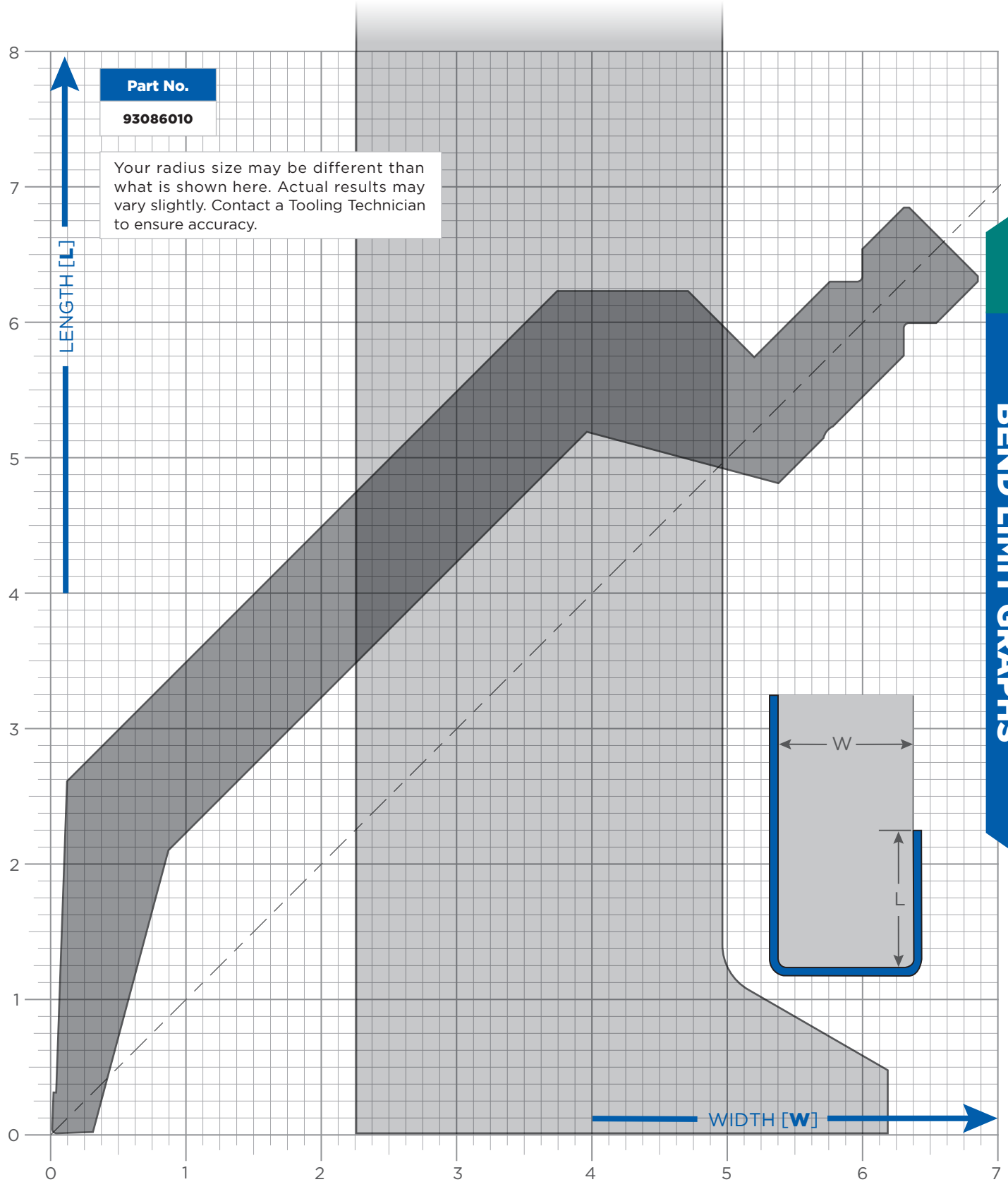

931 — 80° GOOSENECK PUNCH

BEND LIMIT GRAPHS

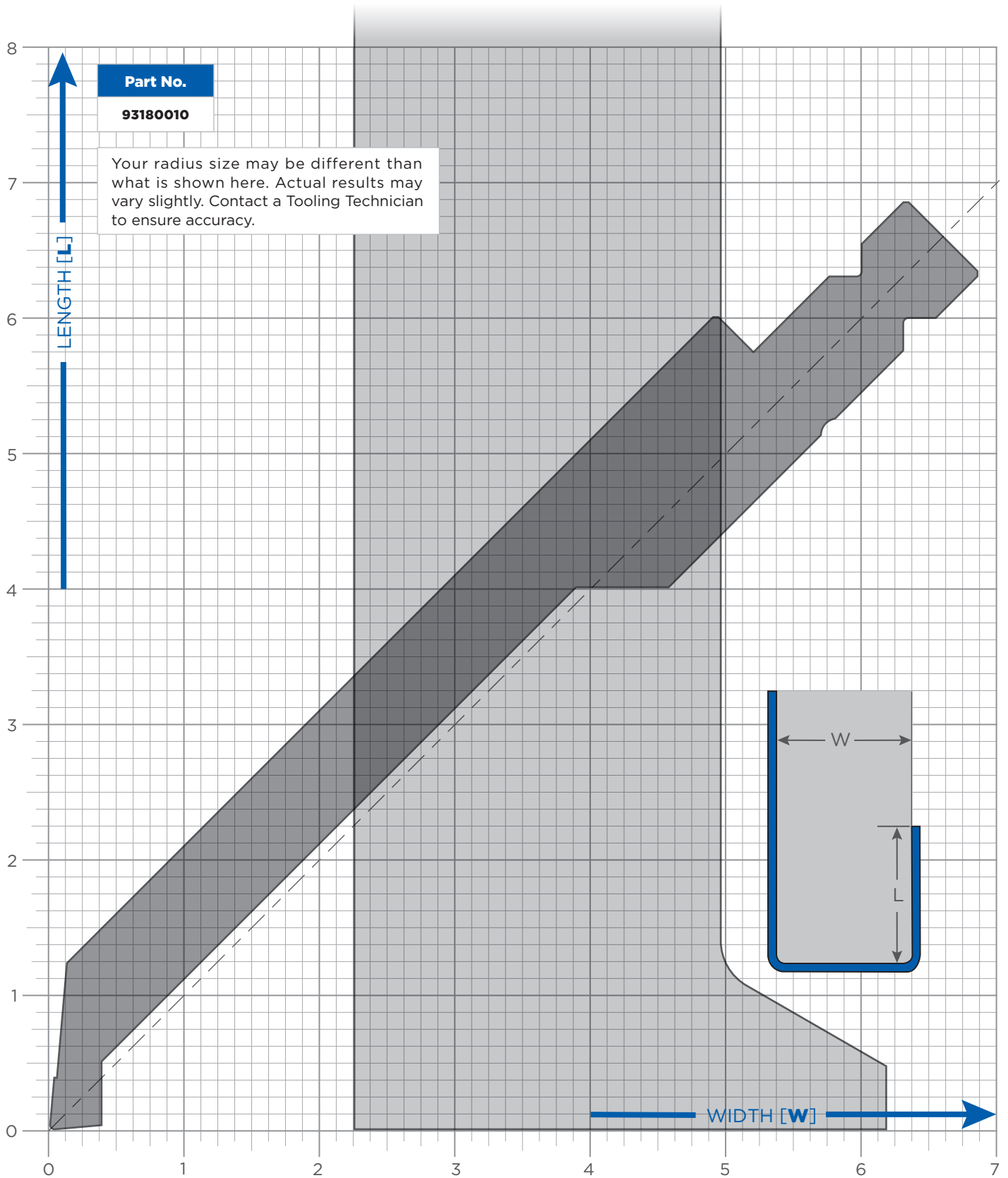

932 – 28° ACUTE PUNCH

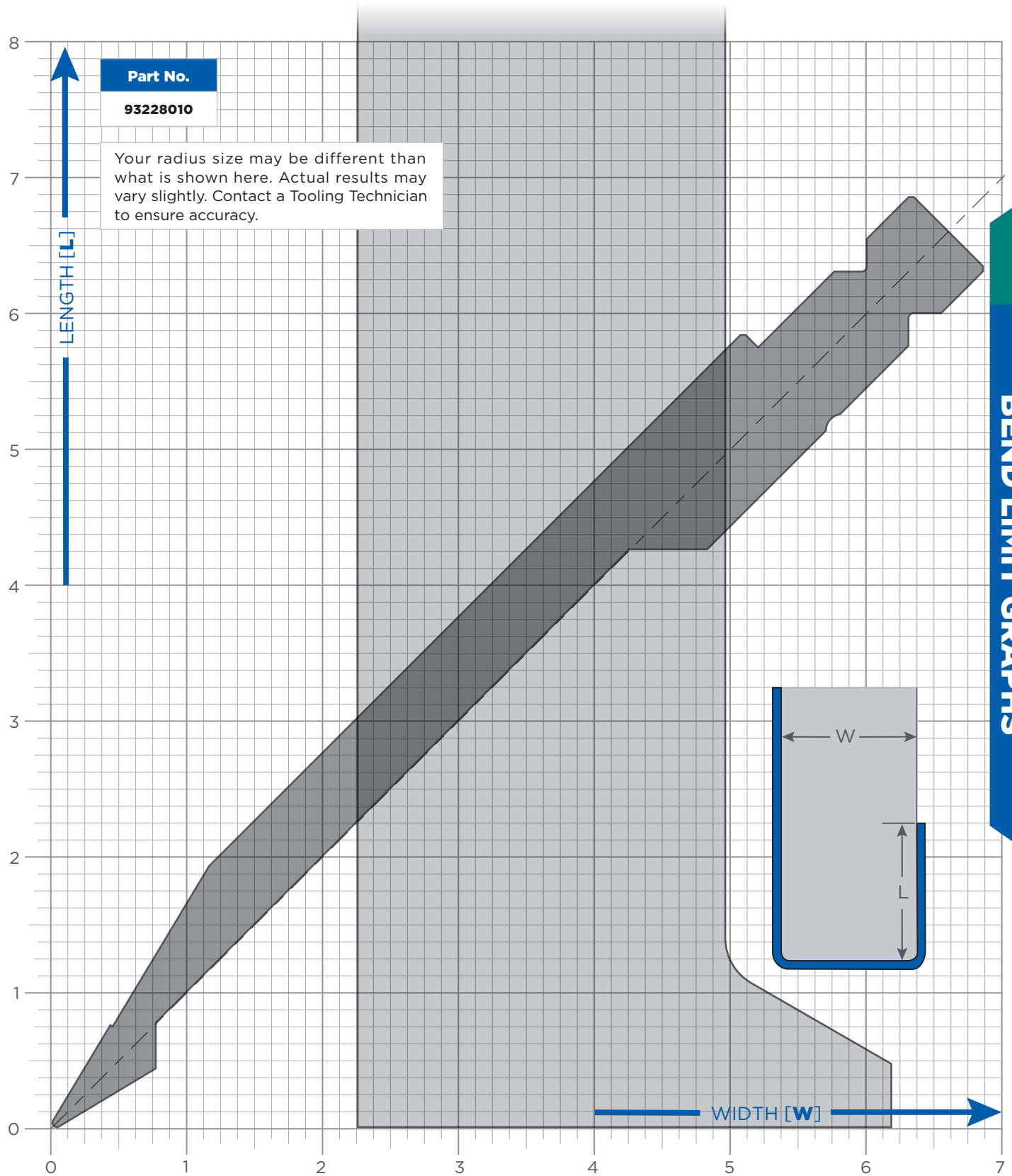

934 – 60° BLOCK PUNCH

BEND LIMIT GRAPHS

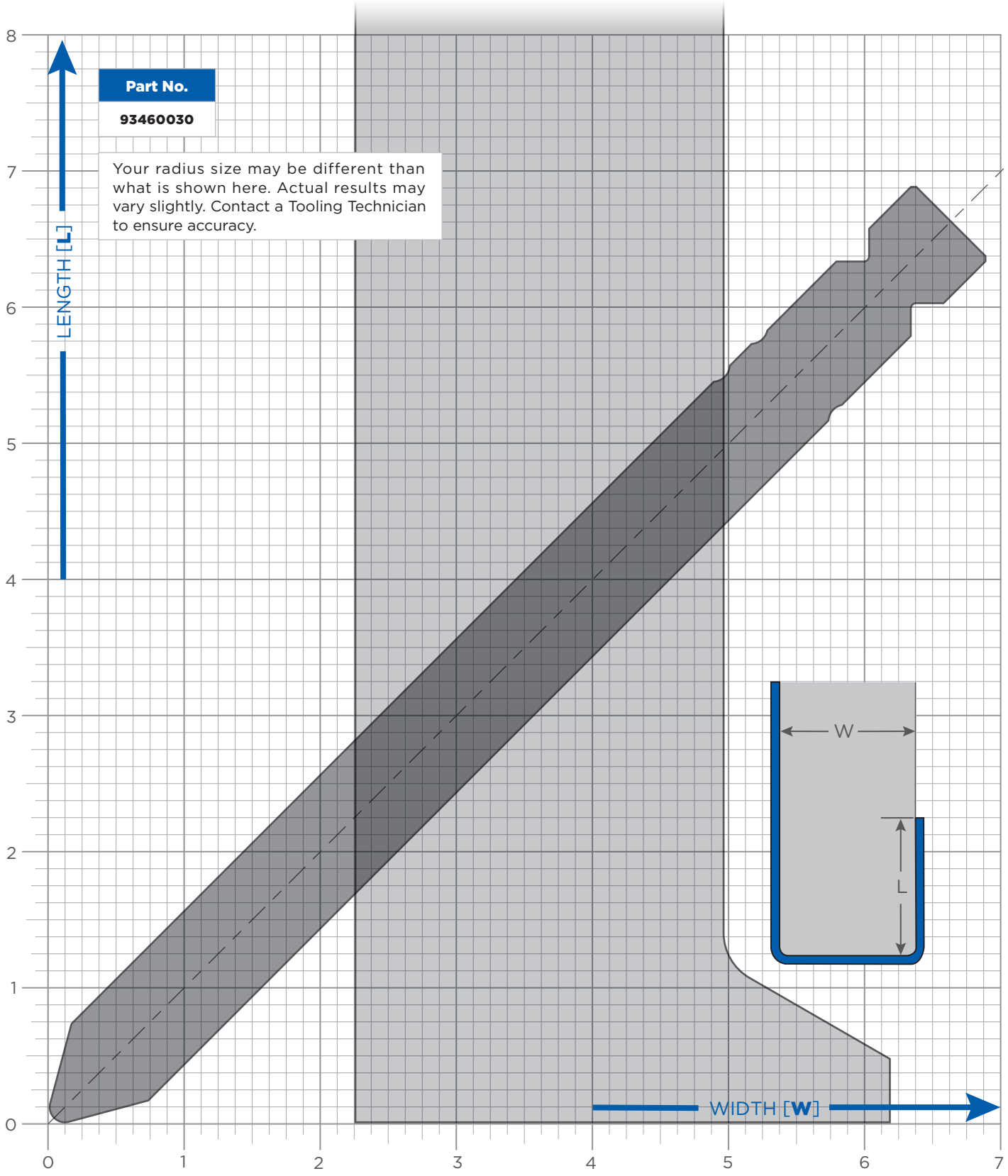

610 – 86° SWAN NECK PUNCH

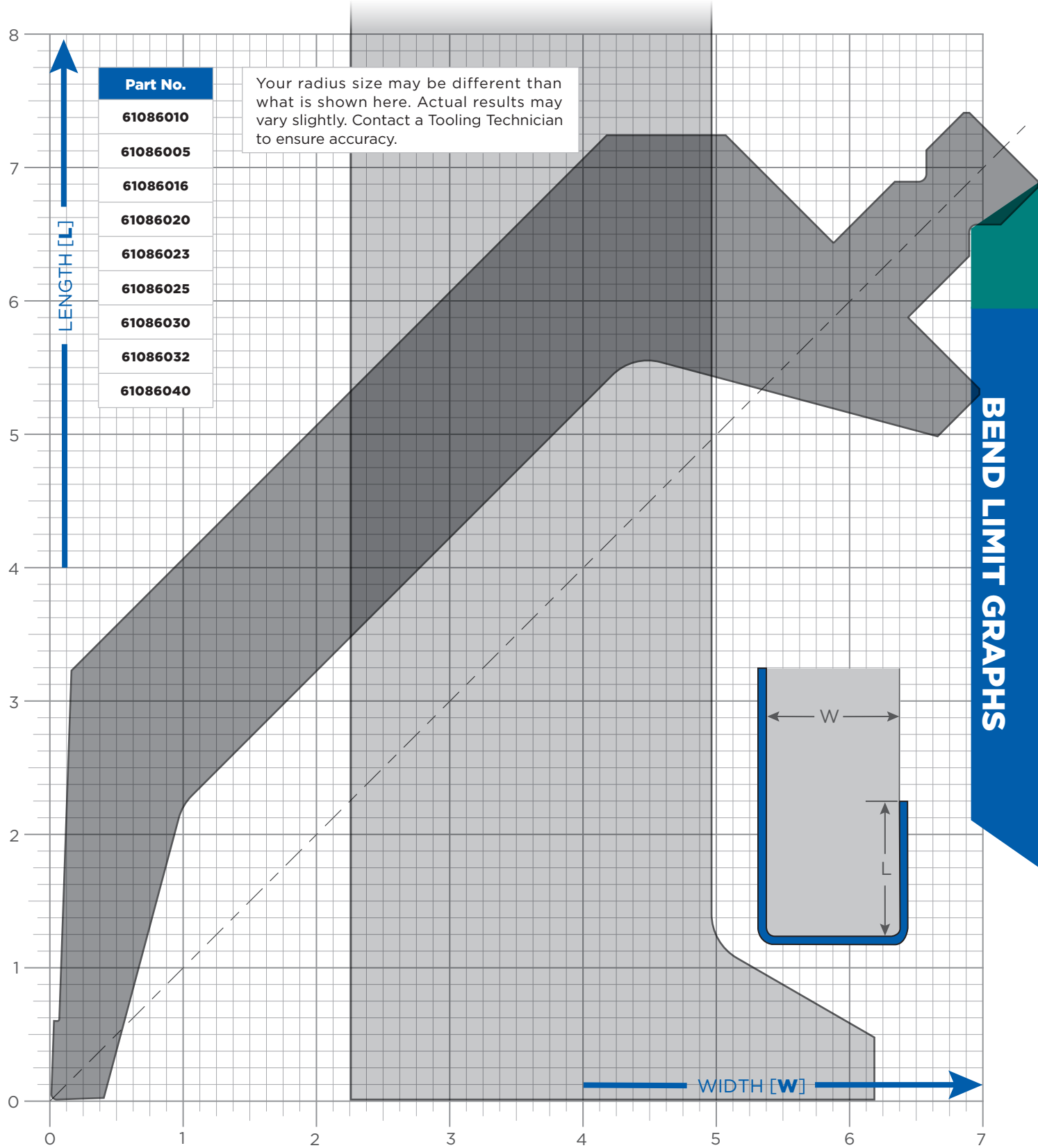

611 – 86° GOOSENECK PUNCH

BEND LIMIT GRAPHS

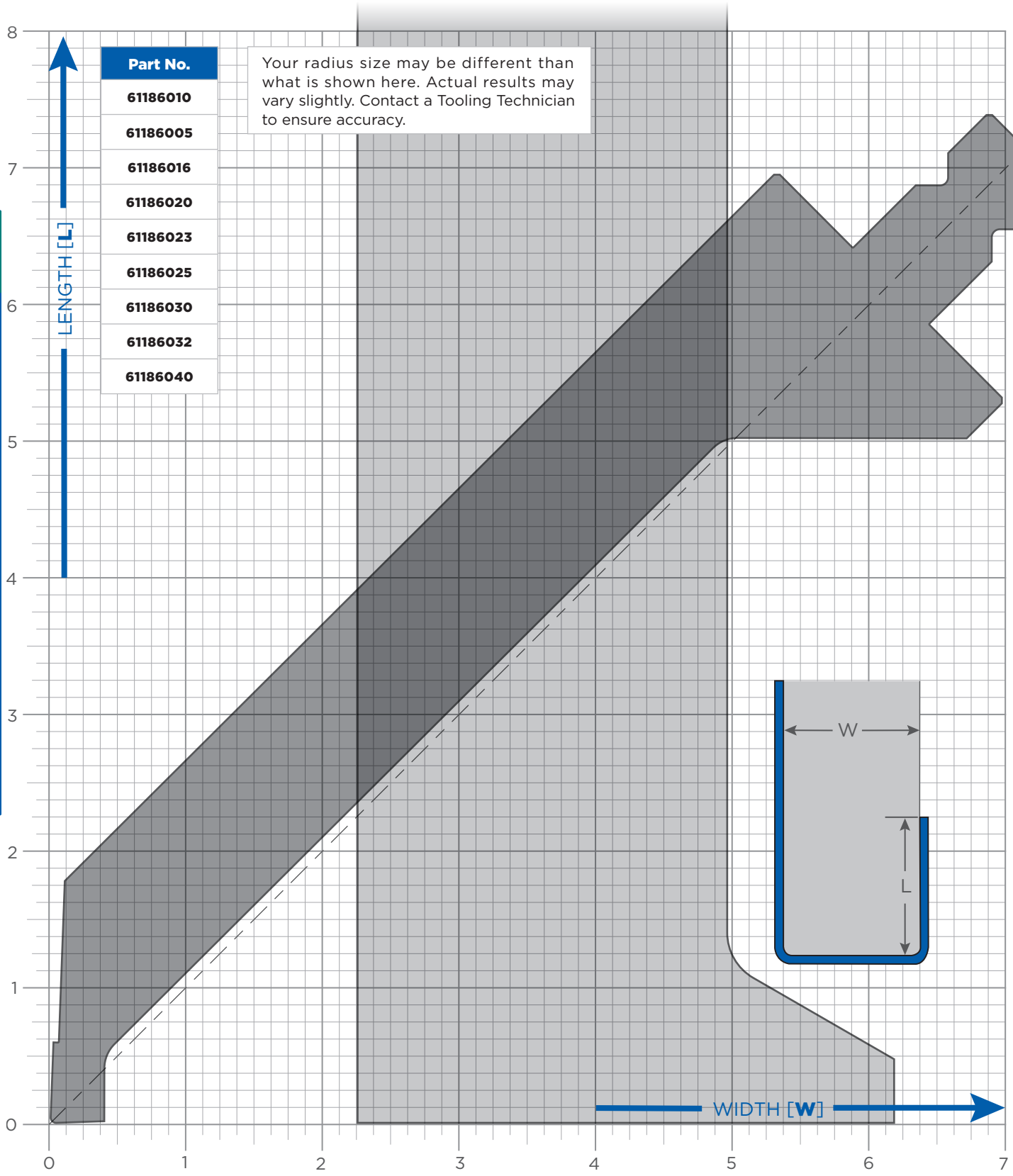

612 – 28° ACUTE WITH RELIEF PUNCH

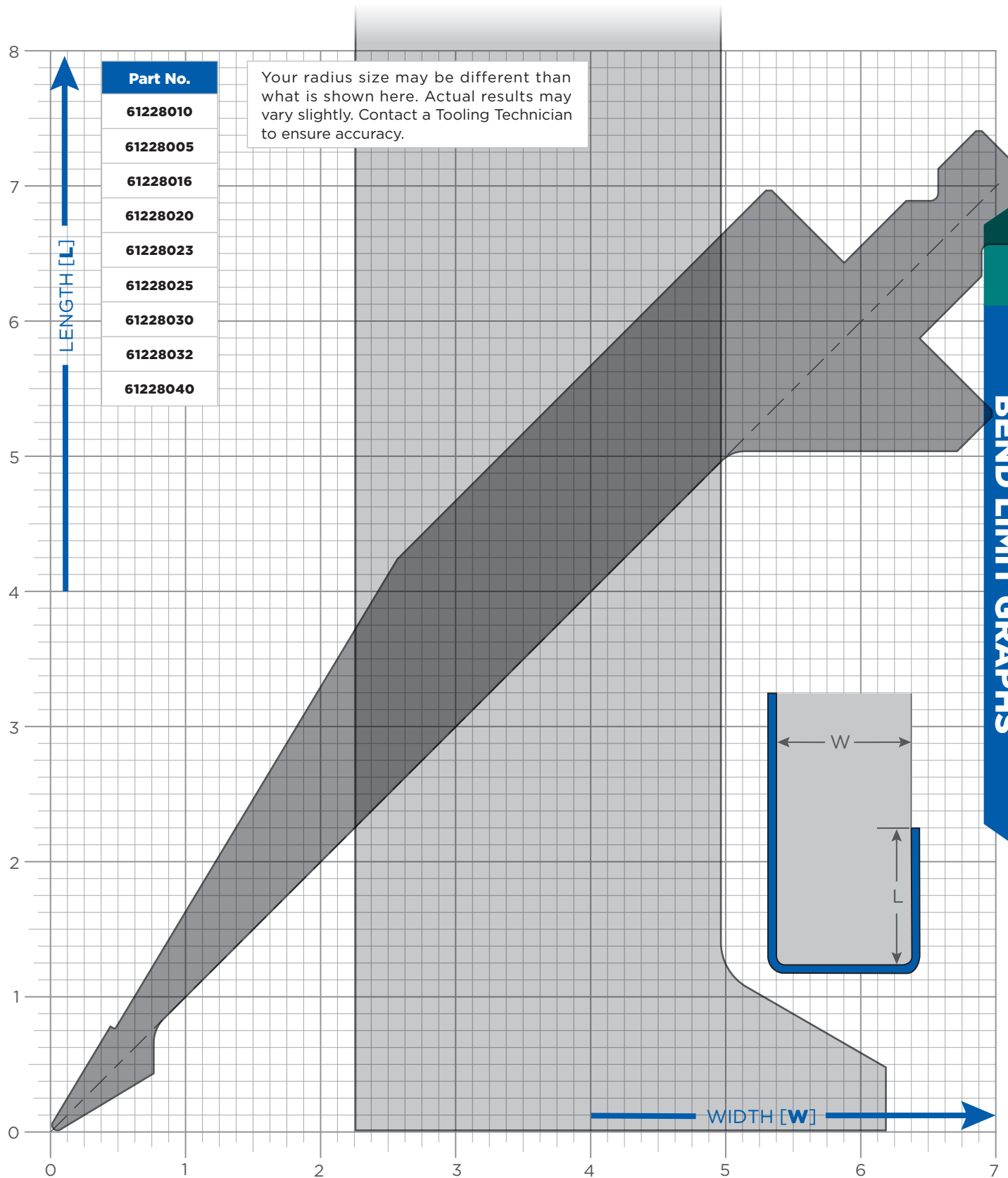

614 — 60° POINTED PUNCH

BEND LIMIT GRAPHS

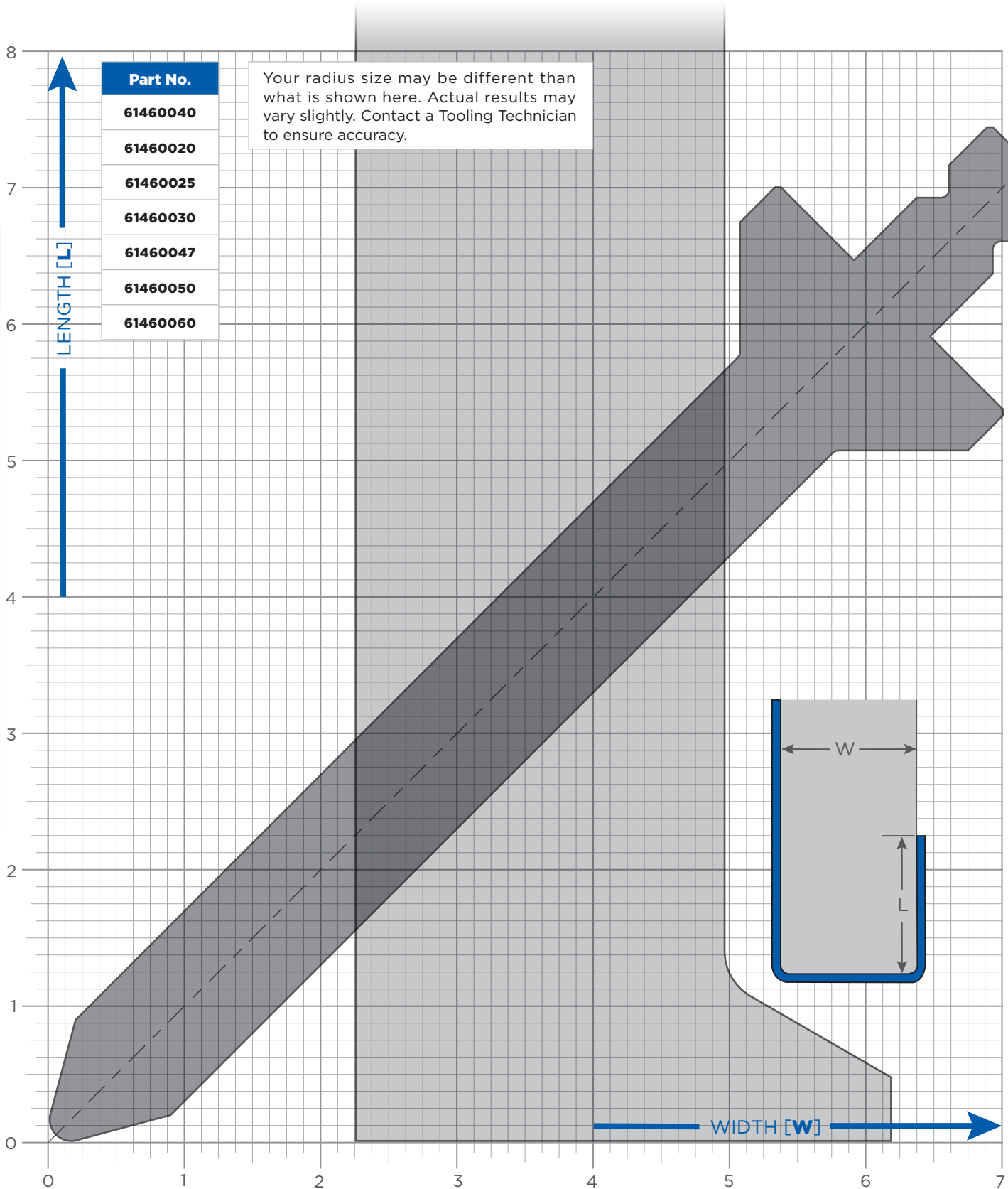

613 — 28° HEMMING PUNCH

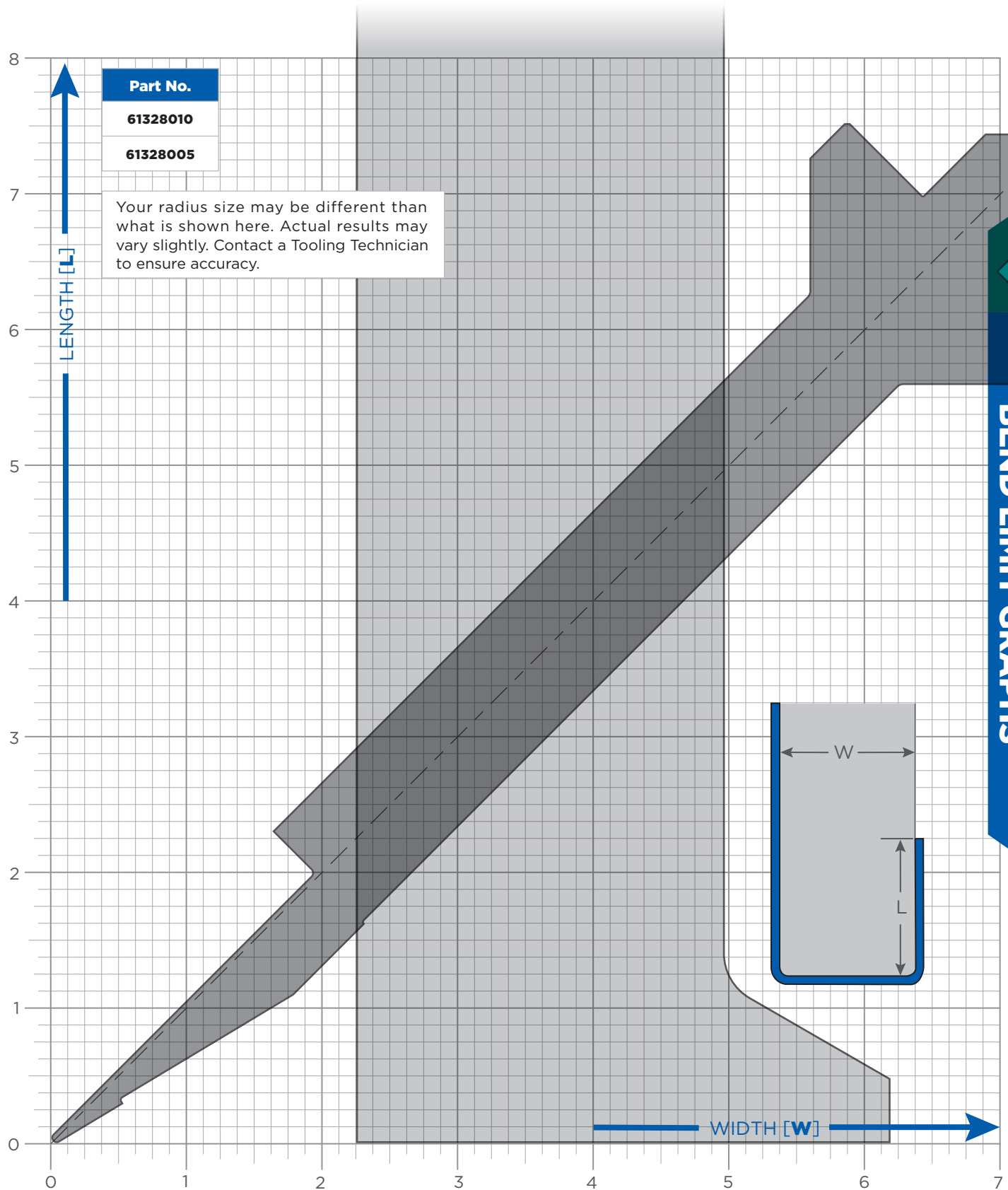

FULL BODY DIES – 100mm TALL

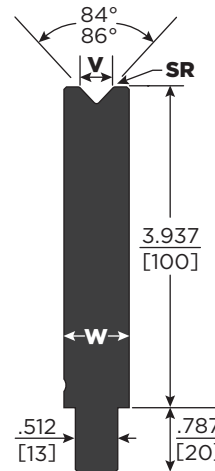

M Made To Order

Part No. [Ref. No.]	Angle	V Opening inch [mm]	W Width inch [mm]	SR Shoulder Radius	kN/m	Max. Ton feet [meter]	Approx. Gross Weight (lbs.)				500 19.685" [500mm]	Sectionalized		
							500	X	X1	X2		X 41.339" [1050mm]	X1 19.685" [500mm]	X2 21.654" [550mm]
SERIES 650 – 100mm TALL DIES														
65084006 [EV W6/84]	M	.236 [6]	.787 [20]	.024 [0.6]	1200	37 [122]	19	40	19	21				
65084008 [EV W8/84]	M	.315 [8]	.787 [20]	.032 [0.8]	1100	34 [112]	19	40	19	21				
65084010 [EV W10/84]	M	.394 [10]	.787 [20]	.039 [1.0]	900	28 [92]	19	40	19	21				
65084012 [EV W12/84]	M	.472 [12]	.984 [25]	.039 [1.0]	1200	37 [122]	23	49	23	26				
65084016 [EV W16/84]	M	.630 [16]	1.181 [30]	.063 [1.6]	1300	40 [133]	27	57	27	30				
65084020 [EV W20/84]	M	.787 [20]	1.181 [30]	.708 [2.0]	1400	43 [143]	27	57	27	30				
65086006 [EV O20/86]		.236 [6]	.787 [20]	.024 [0.6]	1200	37 [122]	19	40	19	21				
65086008 [EV O21/86]		.315 [8]	.787 [20]	.032 [0.8]	1100	34 [112]	19	40	19	21				
65086010 [EV O22/86]		.394 [10]	.787 [20]	.039 [1.0]	900	28 [92]	19	40	19	21				
65086012 [EV O23/86]		.472 [12]	.984 [25]	.039 [1.0]	1200	37 [122]	23	49	23	26				
65086016 [EV O24/86]		.630 [16]	1.181 [30]	.063 [1.6]	1300	40 [133]	27	57	27	30				
65086020 [EV O25/86]		.787 [20]	1.181 [30]	.078 [2.0]	1400	43 [143]	27	57	27	30				
65086024 [EV O26/86]		.945 [24]	1.378 [35]	.098 [2.5]	1500	46 [153]	31	65	31	34				
65086030 [EV O27/86]		1.181 [30]	1.772 [45]	.118 [3.0]	1500	46 [153]	39	81	39	42				
65086040 [EV O28/86]		1.575 [40]	2.165 [55]	.118 [3.0]	1500	46 [153]	45	95	45	50				
65086050 [EV O29/86]		1.969 [50]	2.950 [75]	.118 [3.0]	1500	46 [153]	61	128	61	67				



FULL BODY DIES – 100mm TALL

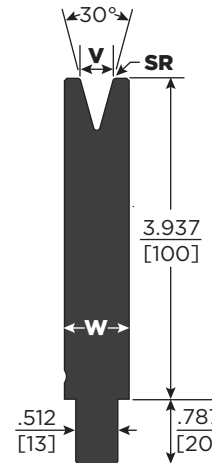

H designation indicates 'with hole' option for hemming

Part No.	Ref. No.	Angle	V Opening inch [mm]	W Width inch [mm]	SR Shoulder Radius	kN/m	Max. Ton feet [meter]	Approx. Gross Weight (lbs.)				Sectionalized			
								500	X	X1	X2	500 19.685" [500mm]	X 41.339" [1050mm]	X1 19.685" [500mm]	X2 21.654" [550mm]
SERIES 650 – 100mm TALL DIES															
65030006	EV001	30°	.236 [6]	.787 [20]	.024 [0.6]	600	18 [61]	19	40	19	21				
65030006H															
65030008	EV002		.315 [8]	.787 [20]	.039 [1.0]	550	17 [56]	19	40	19	21				
65030008H															
65030010	EV003		.394 [10]	.787 [20]	.039 [1.0]	450	14 [46]	19	40	19	21				
65030010H															
65030012	EV004		.472 [12]	.984 [25]	.039 [1.0]	550	17 [56]	23	49	23	26				
65030012H															
65030016	EV005		.630 [16]	1.181 [30]	.063 [1.6]	650	20 [66]	27	57	27	30				
65030016H															
65030020	EV006		.787 [20]	1.378 [35]	.078 [2.0]	650	20 [66]	27	57	27	30				
65030020H															
65030024	EV007		.945 [24]	1.575 [40]	.098 [2.5]	750	23 [76]	32	66	32	34				
65030024H															
65030030	EVW30/30	1.181 [30]	2.165 [55]	.118 [3.0]	750	23 [76]	41	86	41	45					

DIES

FULL BODY DIES – 100mm TALL

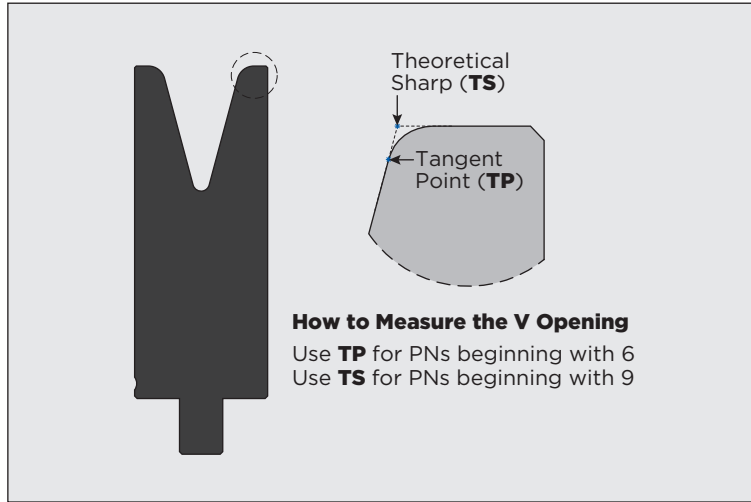
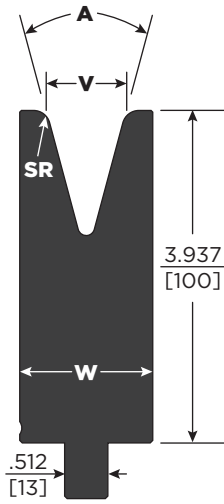

M Made To Order

Part No.	Ref. No.	Angle	V Opening inch [mm]	W Width inch [mm]	SR Shoulder Radius	kN/m	Max. Ton feet [meter]	Approx. Gross Weight (lbs.)				Sectionalized		
								500	X	X1	X2	500 19.685" [500mm]	X 41.339" [1050mm]	X1 19.685" [500mm]
SERIES 652 – 100mm TALL DIES														
65230006	M EV001 R3	30°	.236 [6]	.787 [20]	.118 [3]	600	18 [61]	19	41	19	22			
65230008	M EV002 R3		.315 [8]	.787 [20]		550	17 [56]	19	41	19	22			
65230010	M EV003 R3		.394 [10]	.787 [20]		450	14 [46]	19	41	19	22			
65230012	M EV004 R3		.472 [12]	.984 [25]		550	17 [56]	22	47	22	25			
65230016	M EV005 R3		.630 [16]	1.181 [30]		650	20 [66]	26	55	26	29			

Part No.	Ref. No.	Angle	V Opening inch [mm]	W Width inch [mm]	SR Shoulder Radius	kN/m	Max. Ton feet [meter]	Approx. Gross Weight (lbs.)				Sectionalized		
								200	500	X1	X2	200 7.874" [200mm]	500 19.685" [500mm]	X1 19.685" [500mm]
SERIES 960 – LARGE SHOULDER RADIUS – 100mm TALL DIES														
96030016	M OZU-353	30°	.630 [16]	1.181 [30]	.138 [3.5]	780	27 [80]	10	26	26	28			
96030020	M OZU-363		.787 [20]	1.378 [35]	.157 [4.0]			12	29	29	32			
96030024	M OZU-354		.945 [24]	1.575 [40]	.197 [5.0]			13	32	32	35			
96040030	M OZU-328	40°	1.181 [30]	1.772 [45]	.236 [6.0]	1000	34 [100]	15	39	36	39			
96040040	M OZU-329		1.575 [40]	2.165 [55]	.315 [8.0]	1230	42 [125]	17	41	41	45			



FULL BODY DIES – 100mm / 120mm TALL

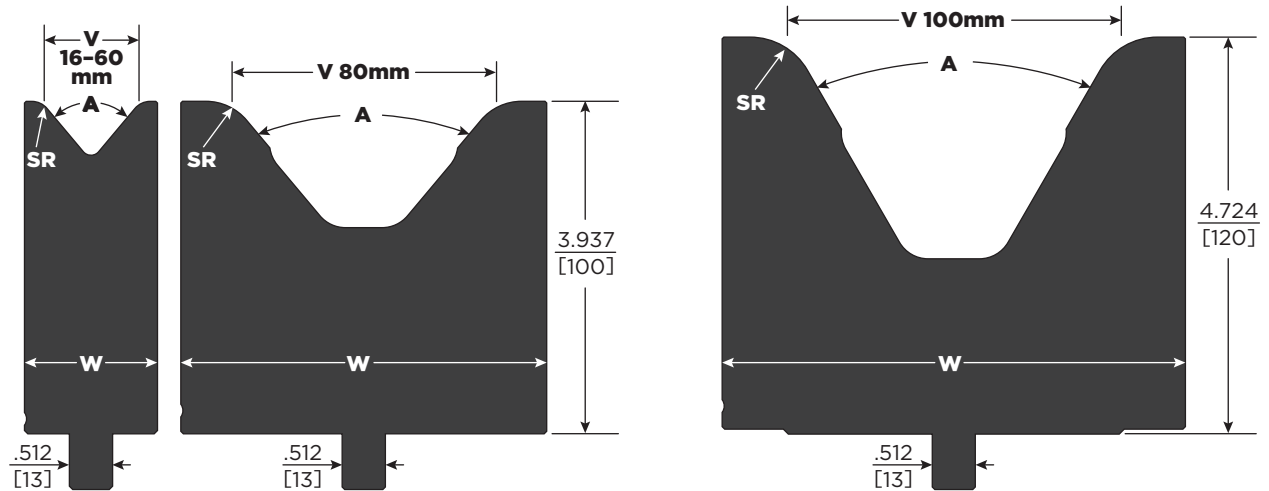

Part No.	Ref. No.	Angle	V Opening inch [mm]	W Width inch [mm]	SR Shoulder Radius	kN/m	Max. Ton feet [meter]	Approx. Gross Weight (lbs.)				Sectionalized	
								200	500	X1	X2	200 7.874" [200mm]	500 19.685" [500mm]
SERIES 960 – LARGE SHOULDER RADIUS – 100mm TALL DIES													
96086016	OZU-312	86°	.630 [16]	.984 [25]	.138 [3.5]	1180	40 [120]	9	23	23	25		
96086020	OZU-323		.787 [20]	1.181 [30]	.157 [4.0]			11	27	27	30		
96080024	OZU-313	80°	.945 [24]	1.378 [35]	.197 [5.0]	1230	42 [125]	12	31	31	34		
96080030	OZU-324		1.181 [30]	1.575 [40]	.236 [6.0]			14	34	34	38		
96080040	OZU-325		1.575 [40]	2.165 [55]	.315 [8.0]			18	45	45	50		
96080050	OZU-326		1.969 [50]	2.56 [65]	.394 [10.0]			21	52	52	57		
96060060	OZU-327	60°	2.362 [60]	3.150 [80]	.472 [12.0]	1230	42 [125]	23	58	58	63		
96080080	OZU-317	80°	3.15 [80]	4.331 [110]	.630 [16.0]	1500	50 [150]	32	80	80	88		
96060080	OZU-372	60°				2200	75 [220]	29	73	73	80		
SERIES 960 – LARGE SHOULDER RADIUS – 120mm TALL DIES													
96080100	OZU-318	80°	3.937 [100]	5.512 [140]	.787 [20.0]	1500	50 [150]	44	110	110	121		
96060100	OZU-373	60°						44	110	110	120		

DIES

FULL BODY DIES – 100mm/120mm TALL

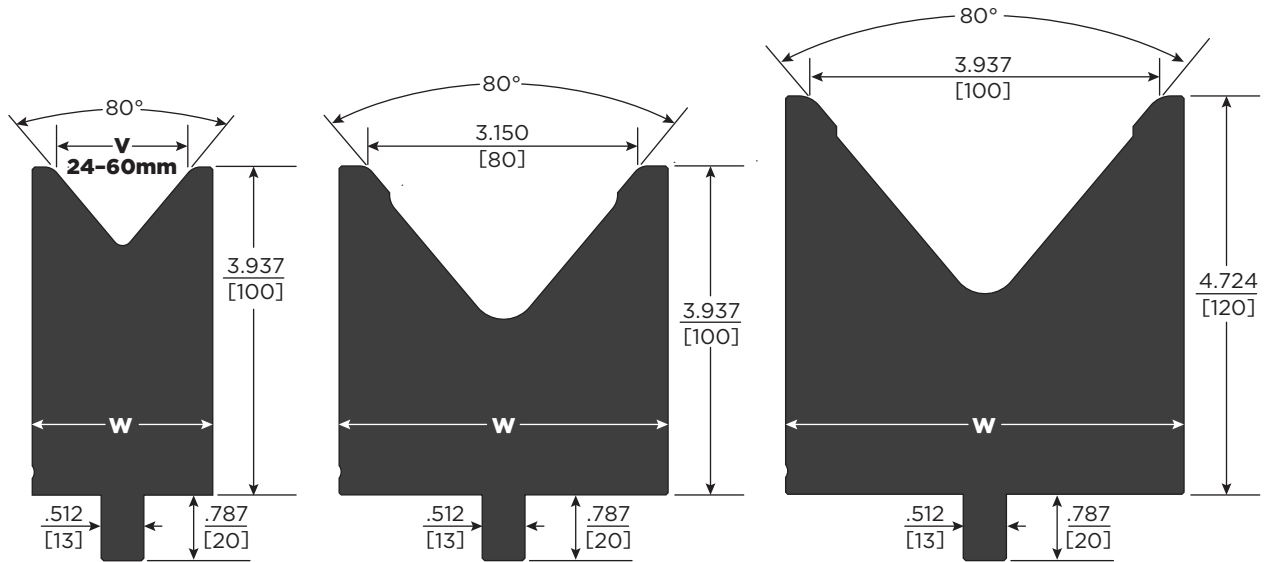

DIES

Part No. [Ref. No.]	Angle	V Opening inch [mm]	W Width inch [mm]	SR Shoulder Radius kN/m	Max. Ton feet [meter]	200 7.874" [200mm]	300 11.811" [300mm]	500 19.685" [500mm]	Sectionalized			
									X 41.339" [1050mm]	X1 19.685" [500mm]	X2 21.654" [550mm]	
SERIES 650 – 100mm TALL DIES												
65080024 EV W24/80	80°	.945 [24]	1.378 [35]	.098 [2.5]	700 [71]	—	—	—	—	—	—	
Approximate Gross Weight Unboxed:						—	—	31 lbs.	65 lbs.	31 lbs.	34 lbs.	
65080030 EV W30/80		1.181 [30]	1.772 [45]	.197 [5.0]	900 [92]	—	—	—	—	—	—	
Approximate Gross Weight Unboxed:						—	—	38 lbs.	81 lbs.	38 lbs.	42 lbs.	
65080040 EV W40/80		1.575 [40]	2.165 [55]	.197 [5.0]	1200 [122]	—	—	—	—	—	—	
Approximate Gross Weight Unboxed:						—	—	45 lbs.	94 lbs.	45 lbs.	49 lbs.	
65080050 EV W50/80		1.969 [50]	2.559 [65]	.197 [5.0]	1500 [153]	—	—	—	—	—	—	
Approximate Gross Weight Unboxed:						—	—	51 lbs.	107 lbs.	51 lbs.	56 lbs.	
65080060 EV W60/80	2.362 [60]	2.953 [75]	.197 [5.0]	1500 [153]	—	—	—	—	—	—		
Approximate Gross Weight Unboxed:						23 lbs.	34 lbs.	—	119 lbs.	57 lbs.	62 lbs.	
65080080 EV W80/80	3.150 [80]	3.937 [100]	.197 [5.0]	1500 [153]	—	—	—	—	—	—		
Approximate Gross Weight Unboxed:						28 lbs.	41 lbs.	—	145 lbs.	69 lbs.	76 lbs.	
SERIES 650 – 120mm TALL DIES												
65080100 EV W100/80	80°	3.937 [100]	4.724 [120]	.315 [8.0]	1500 [153]	—	—	—	—	—	—	
Approximate Gross Weight Unboxed:						39 lbs.	59 lbs.	—	201 lbs.	96 lbs.	105 lbs.	



RELIEVED DIES – 100mm TALL

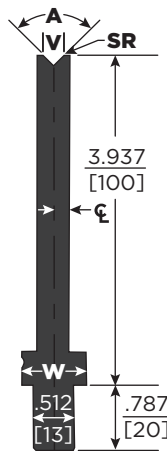

Part No.	Ref. No.	Angle	V Opening inch [mm]	W Width inch [mm]	CL Width inch [mm]	SR Shoulder Radius	kN/m	Max. Ton feet [meter]	500 19.685" [500mm]	Sectionalized		
										X1 19.685" [500mm]	X2 21.654" [550mm]	
SERIES 651 – 100mm TALL DIES												
65184006	EV/S W6/84	84°	.236 [6]	.787 [20]	.197 [5]	.024 [0.6]	250	8 [26]				
Approximate Gross Weight Unboxed:									12 lbs.	12 lbs.	13 lbs.	
65184008	EV/S W8/84		.315 [8]	.787 [20]	.236 [6]	.031 [0.8]	350	11 [36]				
Approximate Gross Weight Unboxed:									13 lbs.	13 lbs.	14 lbs.	
65184010	EV/S W10/84		.394 [10]	.787 [20]	.276 [7]	.039 [1.0]	400	12 [41]				
Approximate Gross Weight Unboxed:									15 lbs.	15 lbs.	16 lbs.	
65184012	EV/S W12/84	.472 [12]	.984 [25]	.315 [8]	.039 [1.0]	500	15 [51]					
Approximate Gross Weight Unboxed:									16 lbs.	16 lbs.	18 lbs.	
65186006	EV O20/S 86	86°	.236 [6]	.787 [20]	.197 [5]	.024 [0.6]	250	8 [26]				
Approximate Gross Weight Unboxed:									12 lbs.	12 lbs.	13 lbs.	
65186008	EV O21/S 86		.315 [8]	.787 [20]	.236 [6]	.031 [0.8]	350	11 [36]				
Approximate Gross Weight Unboxed:									13 lbs.	13 lbs.	14 lbs.	
65186010	EV O22/S 86		.394 [10]	.787 [20]	.276 [7]	.039 [1.0]	400	12 [41]				
Approximate Gross Weight Unboxed:									15 lbs.	15 lbs.	16 lbs.	
65186012	EV O23/S 86	.472 [12]	.984 [25]	.315 [8]	.039 [1.0]	500	15 [51]					
Approximate Gross Weight Unboxed:									17 lbs.	17 lbs.	18 lbs.	

DIES

55mm TALL DIES

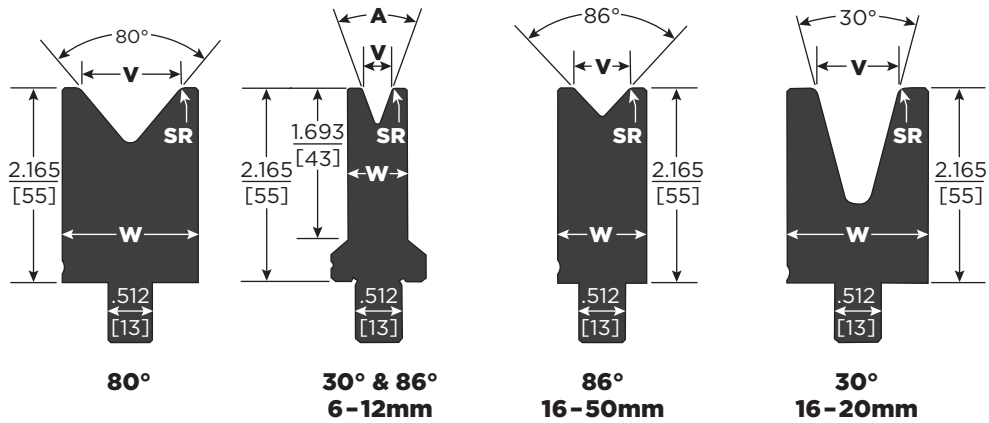

M Made To Order

Part No.	Ref. No.	Angle	V Opening inch [mm]	W Width inch [mm]	SR Shoulder Radius	kN/m	Max. Ton feet [meter]	Approx. Gross Weight (lbs.)				Sectionalized				
								500	X	X1	X2	500 19.685" [500mm]	X 41.339" [1050mm]	X1 19.685" [500mm]	X2 21.654" [550mm]	
SERIES 950 – 55mm TALL DIES																
95030006	M OZU-061	30°	.236 [6]	.630 [16]	.039 [1.0]	780	24 [80]	10	21	10	11					
95030008	M OZU-051		.315 [8]						10	21	10	11				
95030010	M OZU-062		.394 [10]	.787 [20]				11	23	11	12					
95030012	M OZU-052		.472 [12]					11	23	11	12					
95030016	M OZU-053		.630 [16]					14	30	14	16					
95030020	M OZU-063		.787 [20]					15	32	15	17					
95030024	M OZU-054		.945 [24]					17	35	17	18					
95080024	M OZU-013	80°	.945 [24]	1.378 [35]	.098 [2.5]	1230	38 [125]	17	35	17	18					
95080030	M OZU-014		1.181 [30]	1.575 [40]	.118 [3.0]			19	39	19	20					
95080040	M OZU-015		1.575 [40]	1.969 [50]	.157 [4.0]			22	46	22	24					
95080050	M OZU-035		1.969 [50]	2.952 [75]				31	65	31	34					
95086006	M OZU-021	86°	.236 [6]	.630 [16]	.039 [1.0]	1180	36 [120]	19	39	19	20					
95086008	M OZU-010		.315 [8]						19	39	19	20				
95086010	M OZU-022		.394 [10]	.787 [20]				19	39	19	20					
95086012	M OZU-011		.472 [12]					23	49	23	26					
95086016	M OZU-012		.630 [16]					.984 [25]	.059 [1.5]	27	57	27	30			
95086020	M OZU-023		.787 [20]					1.181 [30]	.078 [2.0]	27	57	27	30			

Tooling for special application available upon request.



THIN BODY DIES – 100mm TALL

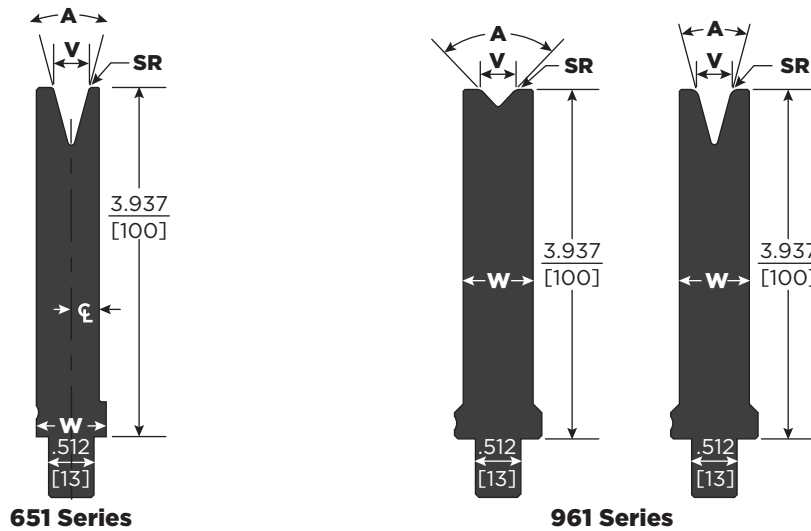

H designation indicates 'with hole' option for hemming.

M Made To Order

Part No.	Ref. No.	Angle	V Opening inch [mm]	W Width inch [mm]	CL Width inch [mm]	SR Shoulder Radius	kN/m	Max. Ton feet [meter]	Approx. Gross Weight (lbs.)				Sectionalized				
									500 19.685" [500mm]	X 41.339" [1050mm]	X1 19.685" [500mm]	X2 21.654" [550mm]					
SERIES 651 – 100mm TALL DIES																	
65130006	M EV001/S	30°	.236 [6]	.787 [20]	.236 [6]	.024 [0.6]	170	6 [17.3]	16	34	16	18					
65130006H																	
65130008	M EV002/S		.315 [8]	.787 [20]	.275 [7]		200	7 [20.3]	17	35	17	18					
65130008H																	
65130010	M EV003/S		.394 [10]	.787 [20]	.315 [8]	.039 [1.0]	200	7 [20.3]	17	35	17	18					
65130010H																	
65130012	M EV004/S	.472 [12]	.984 [25]	.354 [9]		295	9 [25.5]	20	42	20	22						
65130012H																	

Part No.	Ref. No.	Angle	V Opening inch [mm]	W Width inch [mm]	SR Shoulder Radius	kN/m	Max. Ton feet [meter]	Approx. Gross Weight (lbs.)				Sectionalized			
								200 7.874" [200mm]	500 19.685" [500mm]	X1 19.685" [500mm]	X2 21.654" [550mm]				
SERIES 961 – 100mm TALL DIES															
96186006	OZU-321	86°	.236 [6]	.630 [16]	.079 [2.0]	1180	40 [120]	7	16	16	18				
96186008	OZU-310		.315 [8]	.630 [16]	.098 [2.5]			7	16	16	18				
96186010	OZU-322		.394 [10]	.787 [20]	.098 [2.5]			8	19	19	21				
96186012	OZU-311		.472 [12]	.787 [20]	.118 [3.0]			8	19	19	21				
96130006	OZU-361	30°	.236 [6]	.630 [16]	.079 [2.0]	780	27 [80]	7	16	16	18				
96130008	OZU-351		.315 [8]	.630 [16]	.098 [2.5]			7	16	16	18				
96130010	OZU-362		.394 [10]	.787 [20]	.098 [2.5]			8	16	16	18				
96130012	OZU-352		.472 [12]	.787 [20]	.118 [3.0]			8	16	16	18				

V-SERIES BLACK (VSB) DIES – MODELS 1, 2 & 2.5

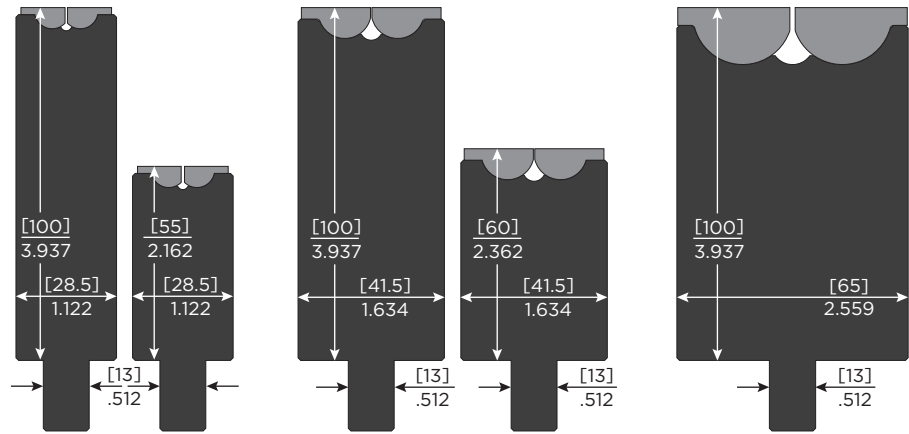

MODEL 1
61100 61055

MODEL 2
62100 62060

MODEL 2.5
625100

Scan QR Code to Watch the Video



V-SERIES BLACK (VSB) DIES

MODEL 1	SOLID				SECTIONAL		X1		X2	
Length	250mm [9.842"]		500mm [19.685"]		550mm [21.654"]		275mm [10.826"]		275mm [10.826"]	
Height	55mm	100mm	55mm	100mm	55mm	100mm	55mm	100mm	55mm	100mm
Assembly Part No.	61055-250	61100-250	61055-500	61100-500	61055-550	61100-550	61055X1	61100X1	61055X2	61100X2
Spring	(20 qty.) 980683	(20 qty.) 981031	(40 qty.) 980683	(40 qty.) 981031	(44 qty.) 980683	(44 qty.) 981031	(22 qty.) 980683	(22 qty.) 981031	(22 qty.) 980683	(22 qty.) 981031
Weight	6 lbs.	10 lbs.	11 lbs.	20 lbs.	13 lbs.	22 lbs.	6 lbs.	11 lbs.	6 lbs.	11 lbs.
Price										
Insert Part No.	-		(4) 980872A		980873A & 980874A		987158		987159	

MODEL 2	SOLID				SECTIONAL		X1		X2	
Length	250mm [9.842"]		500mm [19.685"]		550mm [21.654"]		275mm [10.826"]		275mm [10.826"]	
Height	60mm	100mm	60mm	100mm	60mm	100mm	60mm	100mm	60mm	100mm
Assembly Part No.	62060-250	62100-250	62060-500	62100-500	62060-550	62100-550	62060X1	62100X1	62060X2	62100X2
Spring	(20 qty.) 980682	(20 qty.) 981032	(40 qty.) 980682	(40 qty.) 981032	(44 qty.) 980682	(44 qty.) 981032	(22 qty.) 980682	(22 qty.) 981032	(22 qty.) 980682	(22 qty.) 981032
Weight	9 lbs.	14 lbs.	15 lbs.	25 lbs.	17 lbs.	29 lbs.	8 lbs.	14 lbs.	8 lbs.	14 lbs.
Price										
Insert Part No.	-		(4) 980948		980949 & 980950		987160		987161	

MODEL 2.5	SOLID		X1		X2	
Length	9.84" [250mm]		10.83" [275mm]		10.83" [275mm]	
Height	100mm		100mm		100mm	
Assembly Part No.	625100-250		625100x1		625100x2	
Spring	(20 qty.) 981032		(22 qty.) 981032		(22 qty.) 981032	
Weight	24 lbs.		27 lbs.		27 lbs.	
Price						
Insert Part No.	(2) 990646		(2) 990644		(2) 990645	



Model	Material Thickness inch [mm]	Min. Outside Flange inch [mm]	Ton/ Ft.	Min. Angle	Punch Radius Required @ Min. Angle	Min. Outside Radius @ Min. Angle inch [mm]	Max. Outside Radius @ 90° inch [mm]	US Short Ton/Ft.	Metric Tons/M	kN/M
V-SERIES BLACK (VSB) SPECIFICATIONS										
1	.018 [.45]	.118 [3.0]	1.8	34°	.054	.125 [3.17]	.175 [4.45]	38	112	1100
	.020 [.50]		1.8		.052					
	.024 [.60]		2		.047					
	.032 [.80]		2.5		.036					
	.035 [.90]	3.3	.031							
	.040 [1.0]	4								
	.048 [1.2]	5.8								
	.059 [1.5]	9								
2	.075 [1.9]	.335 [8.5]	7	42°	.122	.216 [5.5]	.354 [9.0]	57	168	1650
	.105 [2.7]	.347 [8.8]	13		.112					
	.118 [3.0]	.366 [9.3]	19		.099					
	.126 [3.2]		22	.091						
	.134 [3.4]	25	55°	.082	.276 [7.9]					
2.5	.079 [2.0]	.732 [18.6]	4	46°	.368	.447 [11.35]	.500 [12.7]	84	250	2450
	.157 [4.0]		16		.221	.378 [9.6]				
	.197 [5.0]		28	55°	.146	.343 [8.71]				

Model	Shoulder Radius inch [mm]	Desired Angle	Theoretical V inch [mm]	Center Line of Inserts inch [mm]
V-OPENING AND SHOULDER RADIUS DIMENSIONS				
1	.043 [1.1]	90°	.283 [7.2]	.315 [8]
		34°	.256 [6.5]	
2	.050 [1.3]	90°	.547 [13.9]	.591 [15]
		42°	.524 [13.3]	
2.5	.079 [2.0]	90°	1.037 [26.3]	1.102 [28]
		55°	1.007 [25.6]	

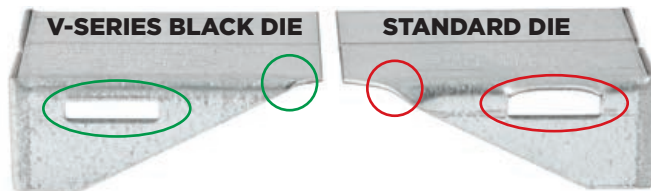

DESCRIPTION	Part No.
INSTALLATION TOOLS	
Spring Installation Tool Kit	981002
Spring Extension Wire (short)	981003
Spring Extension Wire (long)	981004

V-Series Black (VSB) Standard Lengths

Models 1, 2 & 2.5

Solid Length Available: 19.68" [500mm] and 9.84" [250mm]

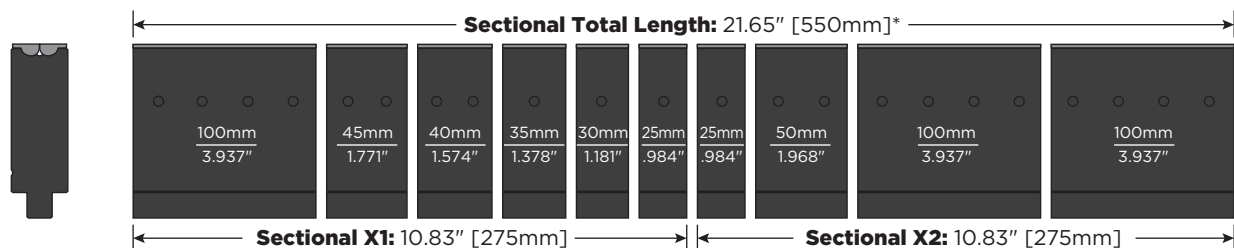

*550mm sectional length not available in Model 2.5

V-SERIES BLACK (VSB) DIES – MODELS 3, 3.5 & 4

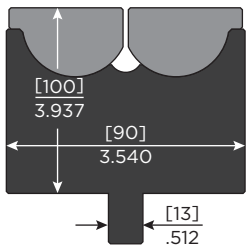

MODEL 3
63070.2

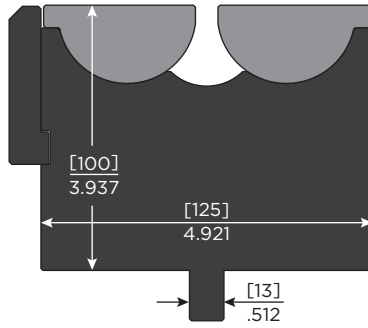

MODEL 3.5
635100

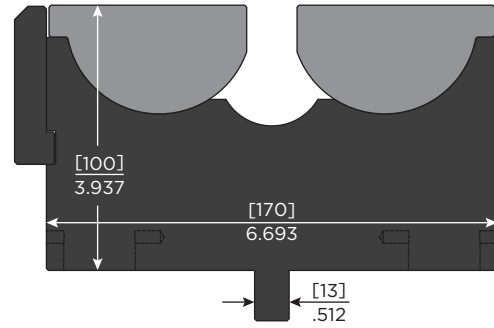

MODEL 4
640100

MODEL 3	SOLID		SECTIONALIZED	
Length	100mm [3.937"]	250mm [9.842"]	455mm [17.913"]	255mm [10.039"]
Height	70mm	70mm	70mm	70mm
Assembly Part No.	63070.2-100	63070.2-250	63070.2-455	63070.2X1
Spring	(4 qty.) 987315	(8 qty.) 987315	(18 qty.) 987315	(10 qty.) 987315
Weight	11 lbs.	27 lbs.	47 lbs.	19 lbs.
Price				
Insert Part No.	987163	980959	987162 & 987163	987162

MODEL 3.5	SOLID		X1
Length	3.94" [100mm]	9.84" [250mm]	10.04" [255mm]
Height	100mm	100mm	100mm
Assembly Part No.	635100-100	635100-250	635100x1
Spring	(4 qty.) 990656	(10 qty.) 990656	(10 qty.) 990656
Weight	20 lbs.	51 lbs.	52 lbs.
Price			
Insert Part No.	(2) 990650	(2) 990651	(2) 990648

MODEL 4	SOLID		X1
Length	3.94" [100mm]	9.84" [250mm]	10.04" [255mm]
Height	100mm	100mm	100mm
Assembly Part No.	640100-100	640100-250	640100x1
Spring	(4 qty.) 990657	(10 qty.) 990657	(10 qty.) 990657
Weight	25 lbs.	62 lbs.	64 lbs.
Price			
Insert Part No.	(2) 990653	(2) 990654	(2) 990652

Model	Material Thickness inch [mm]	Min. Outside Flange inch [mm]	Ton/ Ft.	Min. Angle	Punch Radius Required @ Min. Angle	Min. Outside Radius @ Min. Angle inch [mm]	Max. Outside Radius @ 90° inch [mm]	US Short Ton/Ft.	Metric Tons/M	kN/M
V-SERIES BLACK (VSB) SPECIFICATIONS										
3	.157 [4.0]	.886 [22.5]	12	65°	.078	.453 [11.5]	.625 [15.9]	84	250	2450
	.187 [4.75]		26		.094					
	.250 [6.35]		30		.125					
3.5	.236 [6.0]	1.476 [37.5]	15	75°	—	.267 [6.78]	.945 [24]	84	250	2450
	.315 [8.0]		29		.346 [8.79]					
	.394 [10.0]		49		.425 [10.8]					
4	.236 [6.0]	2.126 [54]	9	78°	—	.267 [6.78]	1.433 [36.4]	101	300	2942
	.315 [8.0]		17	76°		.346 [8.79]				
	.472 [12.0]		44	73°		.503 [12.78]				

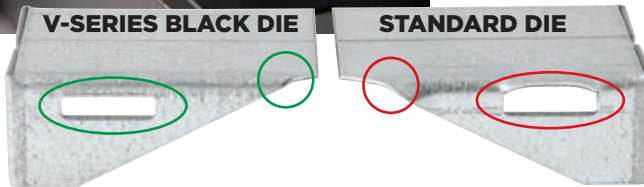

Scan QR Code to Watch the Video

Model	Shoulder Radius inch [mm]	Desired Angle	Theoretical V inch [mm]	Center Line of Inserts inch [mm]
V-OPENING AND SHOULDER RADIUS DIMENSIONS				
3	.236 [6.0]	90°	1.299 [33.0]	1.496 [38]
		65°	1.236 [31.4]	
3.5	.138 [3.5]	90°	2.248 [57.1]	2.362 [60]
		75°	2.226 [56.6]	
4	.236 [6.0]	90°	3.151 [80.0]	3.346 [85]
		73°	3.108 [79.0]	



DESCRIPTION	Part No.
INSTALLATION TOOLS	
Spring Installation Tool Kit	981002
Spring Extension Wire (short)	981003
Spring Extension Wire (long)	981004

V-Series Black (VSB) Standard Lengths

Models 3, 3.5 & 4

Solid Length Available: 9.84" [250mm] and 3.937" [100mm]

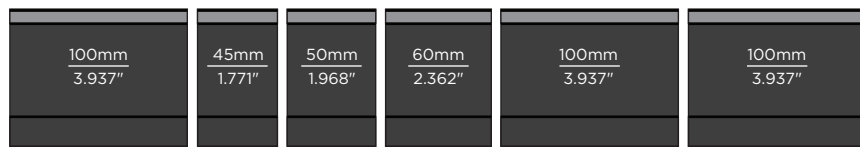
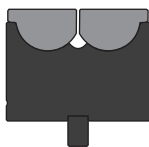

Sectional X1: 10.04" [255mm]

REPLACEABLE RADIUS PUNCHES

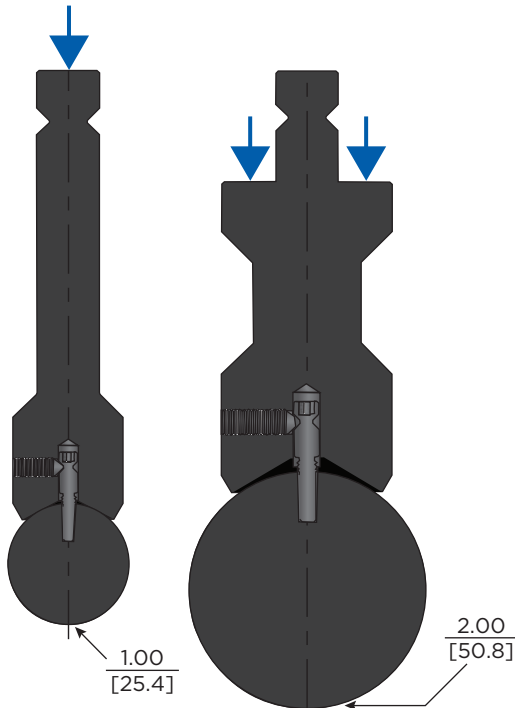

Maximum radius size shown on each holder.

CAUTION: Do not load the radius tip into the holder while in the machine. Remove the holder from the machine to change radius.

HOLDER AND PUNCH TIPS

↓ Indicates how tonnage is applied to punches

Part No.	Radius inch [mm]	Radius Price	Radius Approx. Weight	Holder Part No.	Holder Width inch [mm]	Holder Price	Holder Approx. Weight	Assembled Height inch [mm]	Max. Load
REPLACEABLE RADIUS PUNCHES & HOLDERS — LENGTH: 19.69" [500mm]									
6R095-500	.375 [9.5]		3 lbs.	60T35-500	1.3778 [35]		28 lbs. [12.8]	4.684 [119]	700kN/m 71 T/m 21 T/ft
6R127-500	.500 [12.7]		5 lbs.					4.953 [125.8]	
6R158-500	.625 [15.8]		7 lbs.					5.223 [132.7]	
6R190-500	.750 [19.0]		10 lbs.					5.492 [139.5]	
6R222-500	.875 [22.2]		14 lbs.					5.762 [146.4]	
6R254-500	1.000 [25.4]		18 lbs.	6.031 [153.2]					
6R381-500	1.500 [38.1]		40 lbs.	60T55-500	2.165 [55]	44 lbs. [20.1]	5.606 [142.4]		
6R508-500	2.000 [50.8] MTO		72 lbs.				6.747 [171.37]	7.761 [197.1]	
REPLACEABLE RADIUS PUNCHES & HOLDERS — LENGTH: 9.84" [250mm]									
6R254-250	1.000 [25.4]		9 lbs.	60T55-250	2.165 [55]		22 lbs. [10.5]	5.606 [142.4]	700kN/m 71 T/m 21 T/ft
6R381-250	1.500 [38.1]		20 lbs.					6.747 [171.37]	
6R508-250	2.000 [50.8]		36 lbs.					7.761 [197.1]	

NOTE: The large radius assemblies shown above are not designed to stage bend. Contact a Tooling Technician if stage bending is needed. Make to order (MTO) sizes are available upon request.



OFFSET PUNCH & DIE SETS

- Sold as a set — individual tools available
- Dimensions are shut height requirements less material thickness
- Offset height may vary as much as -.020" [0.5mm] after bending as all angles will be obtuse
- Special offset sizes available at additional cost
- All tonnages are based on direct load and do not apply for thrusting applications

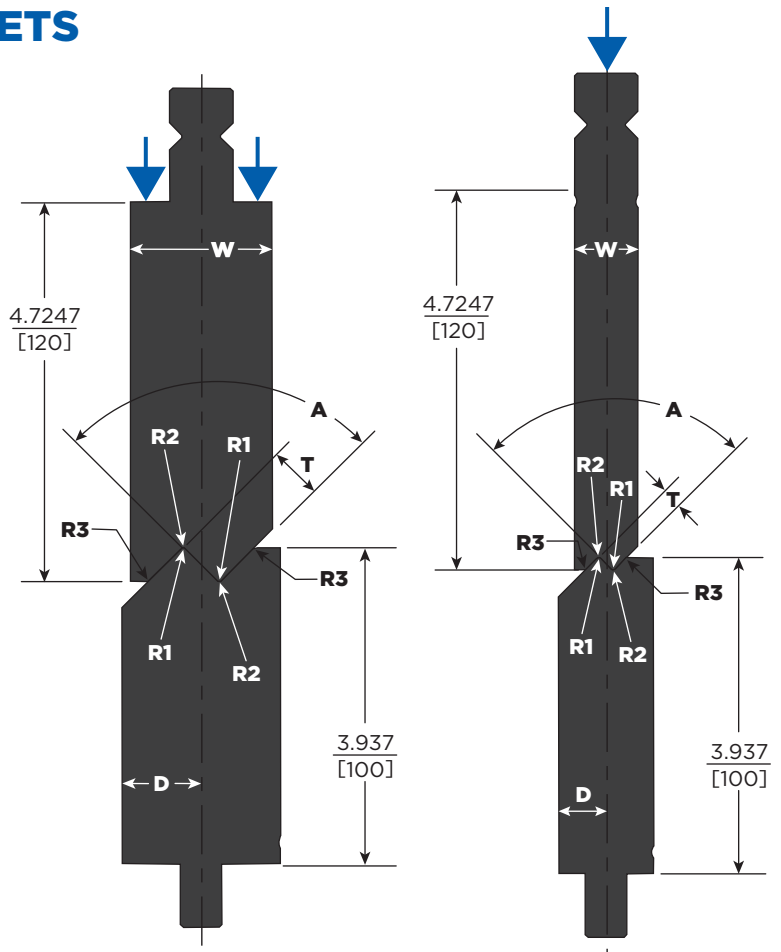

M Made To Order

Part No.	T Offset Dim.** inch [mm]	Effective V inch [mm]	500 19.685" [500mm]	Sectionalized			Load Style	W Width inch [mm]	R1/R2 = Punch & Die Radius inch [mm]	R3 = Shoulder Radius inch [mm]	D Centerline Dimension inch [mm]	Max. Load
				X 41.339" [1050mm]	X1 19.685" [500mm]	X2 21.654" [550mm]						
90° OFFSET PUNCH & DIE SETS												
63190125	.125 [3.2]	.177 [4.5]	46 lbs.	97 lbs.	46 lbs.	51 lbs.	Top	.787 [20]	.024 [.6]	.079 [2]	.394 [10]	1300 kN/m 133 T/m 40 T/ft.
63190157	M .157 [4.0]	.222 [5.6]										
63190188	M .188 [4.8]	.266 [6.8]										
63190236	M .236 [6.0]	.334 [8.5]										
63190250	.250 [6.4]	.354 [9.0]	64 lbs.	132 lbs.	64 lbs.	68 lbs.	Shoulder	1.181 [30]	.039 [1]	.079 [2]	.591 [15]	
63190312	M .312 [7.9]	.441 [11.2]										
63190315	M .315 [8.0]	.445 [11.3]										
63190375	M .375 [9.5]	.530 [13.5]										
63190394	M .394 [10.0]	.557 [14.2]	64 lbs.	132 lbs.	64 lbs.	68 lbs.	Shoulder	1.575 [40]	.039 [1]	.079 [2]	.787 [20]	
63190438	M .438 [11.1]	.619 [15.7]										
63190500	M .500 [12.7]	.707 [17.9]										
63190625	M .625 [15.9]	.884 [22.4]										
63190750	M .750 [19.1]	1.061 [26.9]	64 lbs.	132 lbs.	64 lbs.	68 lbs.	Shoulder	1.969 [50]	.039 [1]	.079 [2]	.984 [25]	

** T= Offset dimension top of sheet to top of form

Ref. No. for Punches: OWZ/K 90° Ref. No. for Dies: EVZ 90°

Approximate Gross Weight Unboxed is shown in blue underneath pricing.

FLATTENING SPACER BLOCK ATTACHMENTS

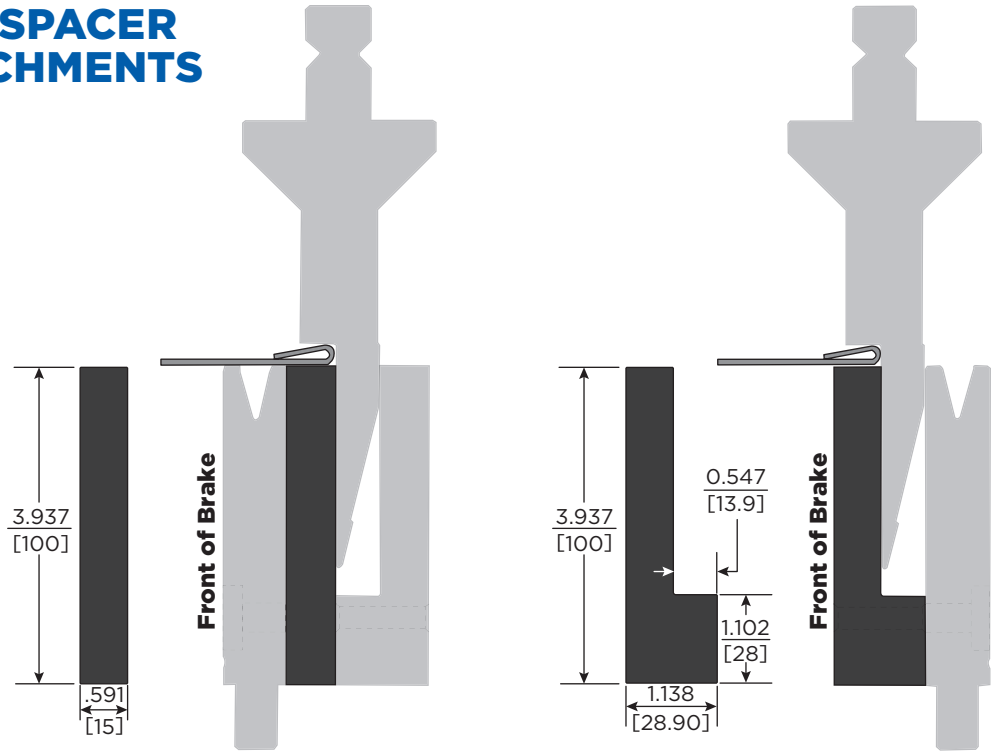

HEMMING & FLATTENING

Part No.	kN/m	Max. Ton ft. [m]	500 19.685" [500mm]	Sectionalized		
				X 41.339" [1050mm]	X1 19.685" [500mm]	X2 21.654" [550mm]
65300001 (I Shape)	1000	31 [102]				
Approximate Gross Weight Unboxed:			12 lbs.	25 lbs.	12 lbs.	13 lbs.
65300002 (L Shape)	1000	31 [102]				
Approximate Gross Weight Unboxed:			16 lbs.	34 lbs.	16 lbs.	18 lbs.

Part No.	V Opening [mm]	500 19.7" [500mm] (7 incl.)	X 41.339" [1050mm] (13 incl.)
MOUNTING HARDWARE KIT			
H/6 - 10	6 - 10		
H/12	12		
H/16	16		
Each kit includes: (2) socket head cap screws; (1) nut			
980883	M8 x 1.25 Hex Nut Class 10		
970508	M8 x 30mm LG socket head cap screw		
8001944	M8 x 45mm LG socket head cap screw		

TWO STAGE HEMMING DIES

Part No.	V1 inch [mm]	H Height inch [mm]	Max. Ton feet [meter]	Approx. Gross Weight		Max. Material	LT 32.874" [835mm]	ST 21.654" [550mm]
				LT	ST			
42601c	.236 [6.0]	4.587 [116.5]	20 [67]	86 lbs.	43 lbs.	20 GA. CRS		
42602c	.315 [8.0]	4.587 [116.5]	20 [67]	86 lbs.	43 lbs.	16 GA. CRS		
42603c	.394 [10.0]	4.902 [124.5]	20 [67]	86 lbs.	43 lbs.	14 GA. CRS		
42608c	.394 [10.0]	5.402 [137.2]	25 [83]	89 lbs.	45 lbs.	14 GA. CRS		

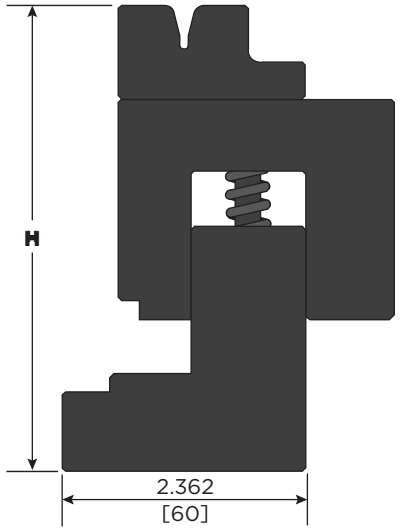

TWO STAGE HEMMING

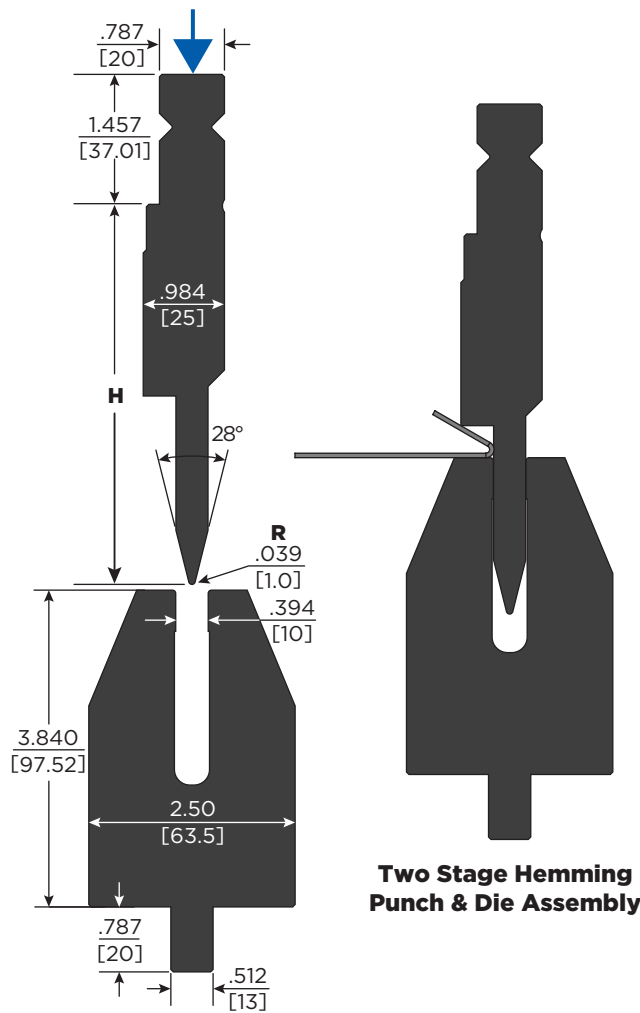

FLATTENING SET

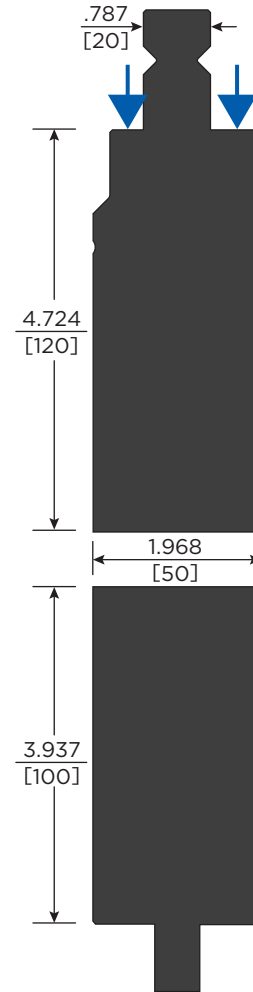

Part No.	H Height inch [mm]	kN/m	Max. Ton feet[meter]	Sectionalized			
				500 19.685" [500mm]	X 41.339" [1050mm]	X1 19.685" [500mm]	X2 21.654" [550mm]
28° TWO STAGE HEMMING PUNCH							
69528010	5.512 [140]	1000	31 [102]				
Approximate Gross Weight Unboxed:				27 lbs.	57 lbs.	27 lbs.	30 lbs.
60528010	4.724 [120]	1000	31 [102]				
Button Options:				P	B1	B1	B1
Approximate Gross Weight Unboxed:				23 lbs.	49 lbs.	23 lbs.	26 lbs.
TWO STAGE HEMMING DIE							
65530010	—	1000	31 [102]	—	—	—	
Approximate Gross Weight Unboxed:				46 lbs.	—	—	—

Part No.	Max. Ton	500 19.685" [500mm]	Sectionalized	
			X1 19.685" [500mm]	X2 21.654" [550mm]
FLATTENING PUNCH				
69500000	1300 kN/m 133 T/m 40 T/ft.			
Button Options:		P	B2	B2
Approximate Gross Weight Unboxed:		57 lbs.	57 lbs.	62 lbs.
FLATTENING DIE				
65300003	1300 kN/m 133 T/m 40 T/ft.			
Approximate Gross Weight Unboxed:		55 lbs.	55 lbs.	61 lbs.

Tonnage is based on direct load and does not apply for thrusting applications.
Maximum material is 16 ga. cold rolled steel.

HEMMING & FLATTENING

PUNCH HOLDERS

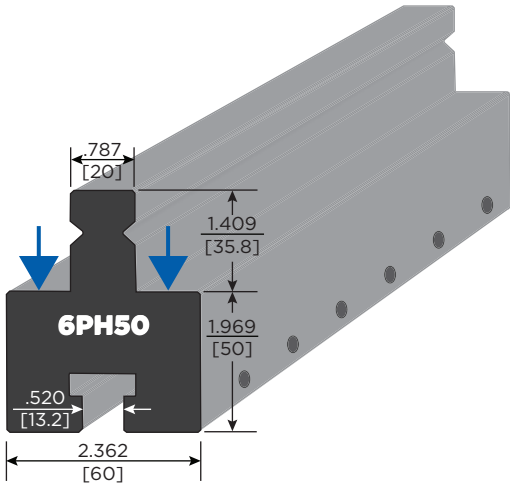

Part No.	H Height inch [mm]	kN/m	Max. Ton feet [meter]	500 19.685" [500mm]	Sectionalized		
					X 41.339" [1050mm]	X1 19.685" [500mm]	X2 21.654" [550mm]
WT TO AMERICAN PUNCH HOLDER							
6PH50	1.969 [50]	1900	60 [197]				
Button Options:				P	P/B3	B3	P/B3
Approximate Gross Weight, Unboxed:				28 lbs.	59 lbs.	28 lbs.	31 lbs.

Tonnage is based on direct load and does not apply for thrusting applications.
Set screws every 2".

HOLDERS

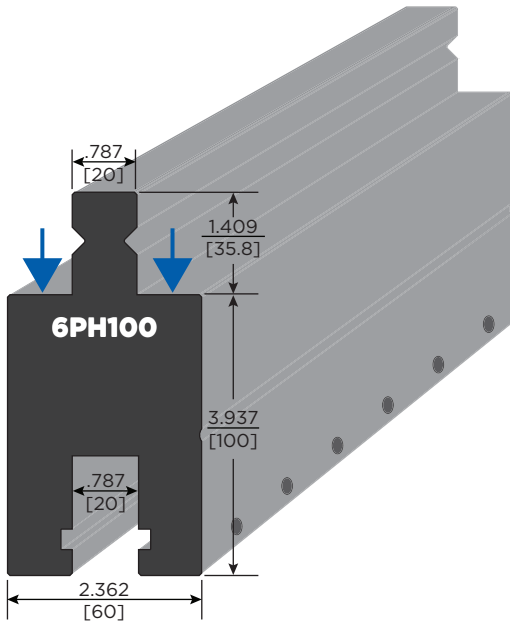

Part No.	H Height inch [mm]	kN/m	Max. Ton feet [meter]	500 19.685" [500mm]	Sectionalized		
					X 41.339" [1050mm]	X1 19.685" [500mm]	X2 21.654" [550mm]
WT TO WT PUNCH HOLDER							
6PH100	3.937 [100]	2300	70 [232]				
Button Options:				P	P/B3	B3	P/B3
Approximate Gross Weight, Unboxed:				51 lbs.	109 lbs.	51 lbs.	5 lbs.

Tonnage is based on direct load and does not apply for thrusting applications.
Set screws every 2".



PUNCH HOLDERS

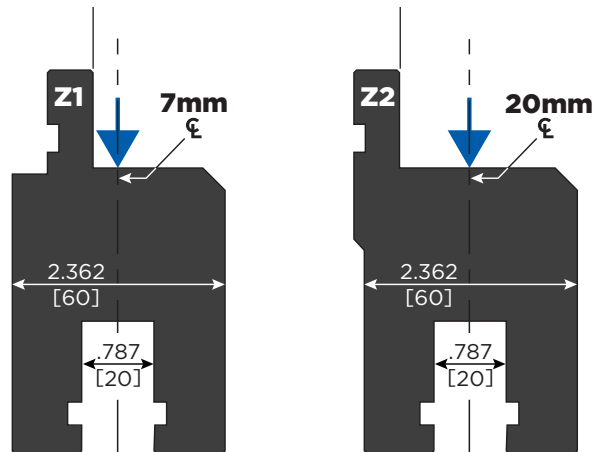

Part No.	Mount Style	kN/m	Max. Ton feet [meter]	500 19.685" [500mm]	Sectionalized		
					X 41.339" [1050mm]	X1 19.685" [500mm]	X2 21.654" [550mm]
EUROPEAN TO WT PUNCH HOLDER							
4PH	Z1	1900	60/197	Lengths and heights are configurable to your needs. Call for price.			
	Z2						

Tonnage is based on direct load and does not apply for thrusting applications.

DIE HOLDER

Part No.	H Height inch [mm]	kN/m	Max. Ton feet [meter]	500 19.685" [500mm]	Sectionalized		
					X 41.339" [1050mm]	X1 19.685" [500mm]	X2 21.654" [550mm]
WT TO WT DIE HOLDER							
6DH45	1.772 [45]	1700	52 [175]				
Approximate Gross Weight, Unboxed:				16 lbs.	34 lbs.	16 lbs.	17 lbs.

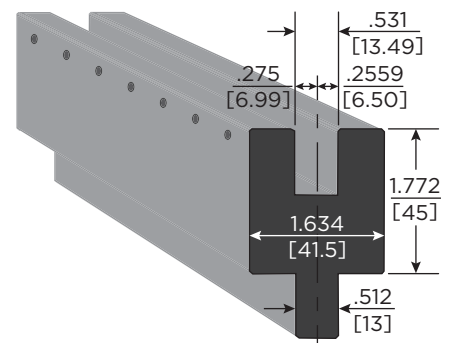

Tonnage is based on direct load and does not apply for thrusting applications.

Set screws every 2".

HOLDERS

URETHANE DIE HOLDERS & PADS

All urethane die holders are machined from 6061-T6 aluminum.
Check height against machine stroke prior to ordering.

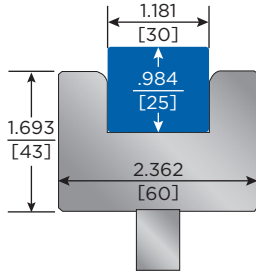

M Made To Order

Part No.	Description/ Shore Hardness	L	S	L	S
		Appx. Gross Weight	32.874" [835mm]	16.338" [415mm]	
42501c	M Holder	10 lbs.	6 lbs.		
42511	Pad 80A Red	2 lbs.	1 lbs.		
42521	Pad 90A Blue	2 lbs.	1 lbs.		

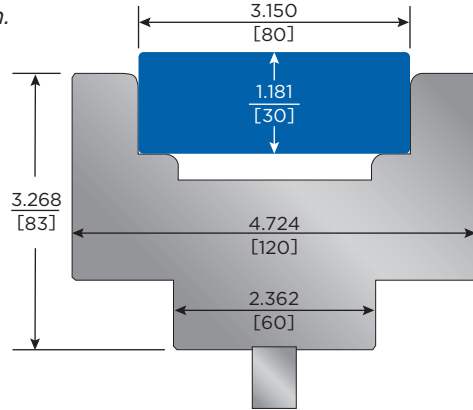

M Made To Order

Part No.	Description/ Shore Hardness	L	S	L	S
		Appx. Gross Weight	32.874" [835mm]	16.338" [415mm]	
42503c	M Holder	35 lbs.	19 lbs.		
42513	Pad 80A Red	6 lbs.	3 lbs.		
42523	Pad 90A Blue	6 lbs.	3 lbs.		

HOLDERS

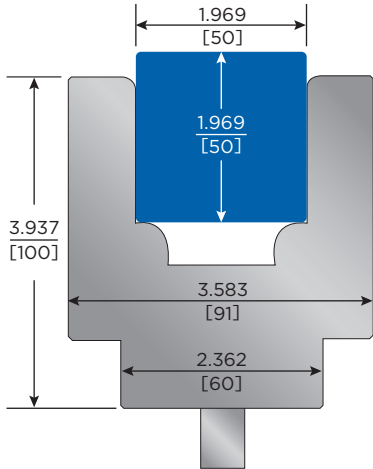

M Made To Order

Part No.	Description/ Shore Hardness	L	S	L	S
		Appx. Gross Weight	32.874" [835mm]	16.338" [415mm]	
42502c	M Holder	33 lbs.	17 lbs.		
42512	Pad 80A Red	6 lbs.	3 lbs.		
42522	Pad 90A Blue	6 lbs.	3 lbs.		

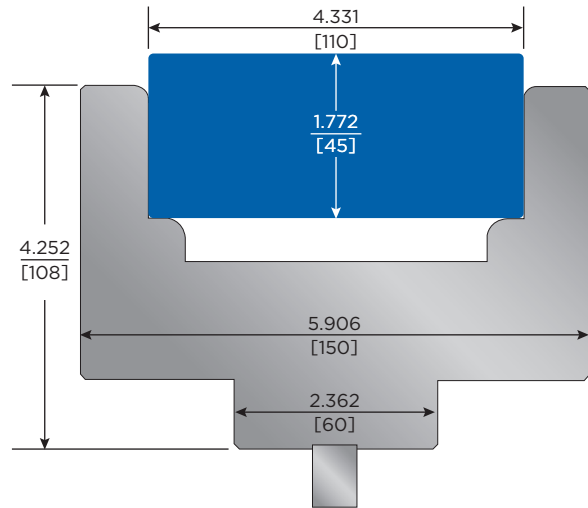

M Made To Order

Part No.	Description/ Shore Hardness	L	S	L	S
		Appx. Gross Weight	32.874" [835mm]	16.338" [415mm]	
42504c	M Holder	52 lbs.	27 lbs.		
42514	Pad 80A Red	11 lbs.	6 lbs.		
42524	Pad 90A Blue	11 lbs.	6 lbs.		



SPECIAL TOOLING



EUROPEAN



WT-STYLE



AMERICAN



RFA-STYLE

CHALLENGE OUR “NEVER SAY NO” ATTITUDE

We regularly help customers with their most challenging applications. Our innovative solutions simplify complex bends and make the impossible possible. We are defined by our “never say no” attitude. Bring us your most complex problem and we will work with you until we’ve found an effective solution.

Quality Materials — Quality Control

We combine premium materials with specialized manufacturing systems to produce extraordinary products that outlast the competition.

Quick Quotes — Short Lead Times

With the fastest lead times in the industry, our tool might ship before the competition even provides a quote.

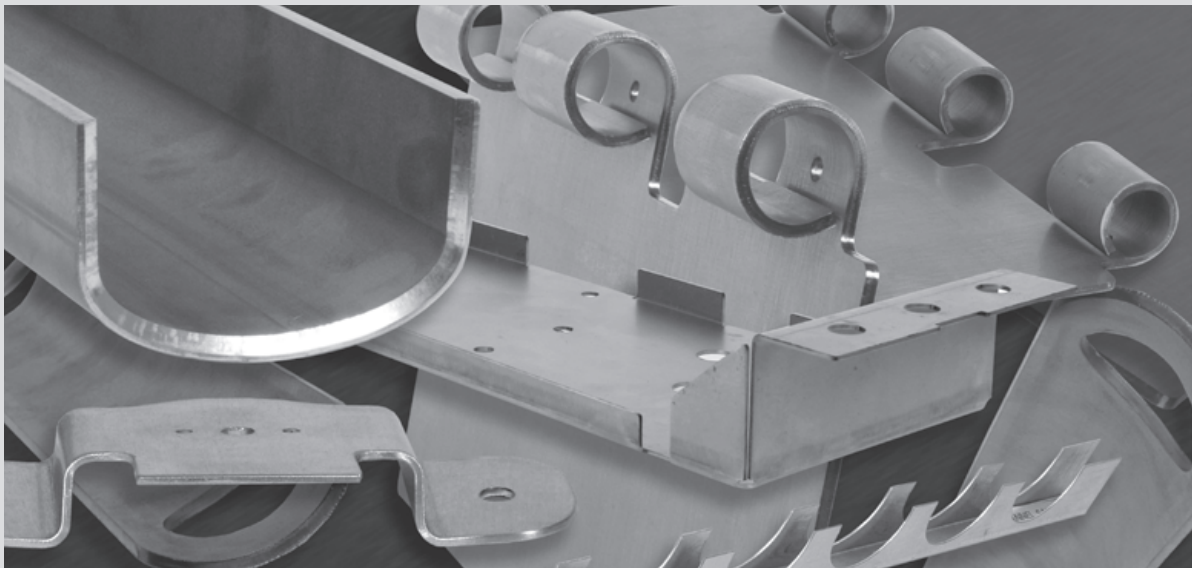

SPECIALS

BRAKE PARTNER®

Make Punch Press Forms in the Press Brake

For fabricators who have migrated away from punch presses to laser cutting machines, or for those whose punch presses are running at full capacity, Brake Partner® from Wilson Tool International is an especially helpful solution.

Brake Partner, manufactured to fit in virtually any press brake, features a pressure-pad system which provides blank-holding and stripping, and can be used with or without guide posts, depending on the application.

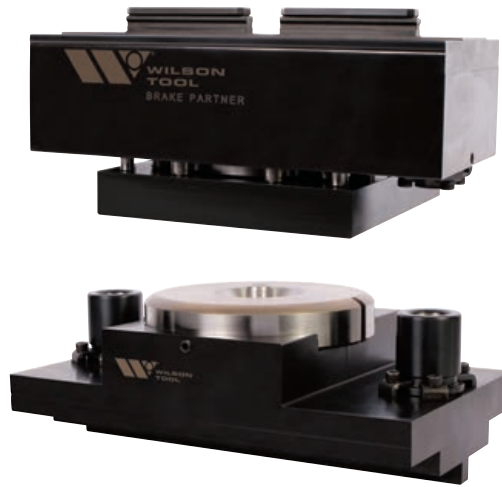

Enjoy These Cost Saving Benefits

- Reduce press brake special tooling costs
- Punch press tooling has shorter lead times
- Put your existing press brakes to work on applications that were previously impossible on a punching machine
- Reduce outsourcing of punching applications
- Streamline equipment usage and create more flexibility in your shop



Scan QR Code to
Watch the Video



CORNER FORMER

To make a four-sided tray or door, the sides would traditionally be folded, the corners welded and the joint ground, to produce an acceptable finish. This process is time consuming, costly and requires a certain skill set.

The Corner Former from Wilson Tool International allows you to use your existing press brake to bend up the corners, form the corners and then crop the edges to leave a clean, finished look without the need for welding, grinding and finishing.

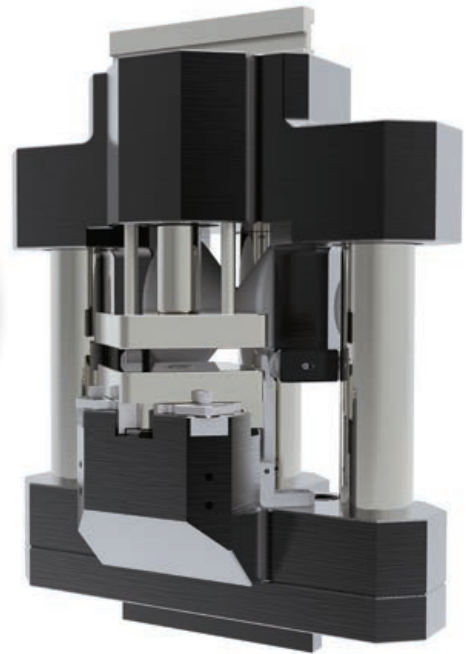
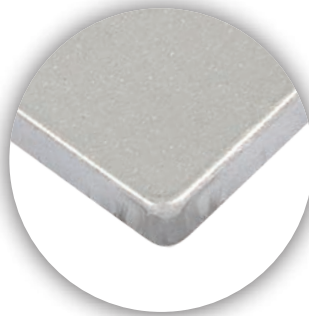

3 SIMPLE STEPS TO A FINISHED CORNER



Step 1: Bend with Flare

All four corners are bent like any other part except your standard die will have an engineered relief to achieve an intentionally flared bend at the ends.

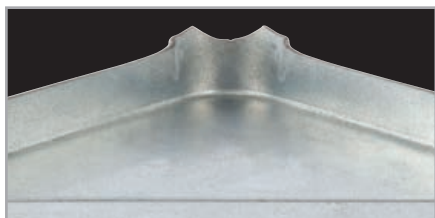

Step 2: Corner Former

After the engineered flare, the part is moved to the corner forming step to roll the edge. You now have a complete corner with extra material that needs to be trimmed.



Step 3: Corner Cropper/Trim

In a quick and simple one-hit action, the corner cropper cuts the extra material flush to the edges of the tray or door. You have now made your part in one handling with little or no additional post processing needed.



Scan QR Code to Watch the Video



Scan QR Code to See How Much You Can Save



CUSTOM HEMMING

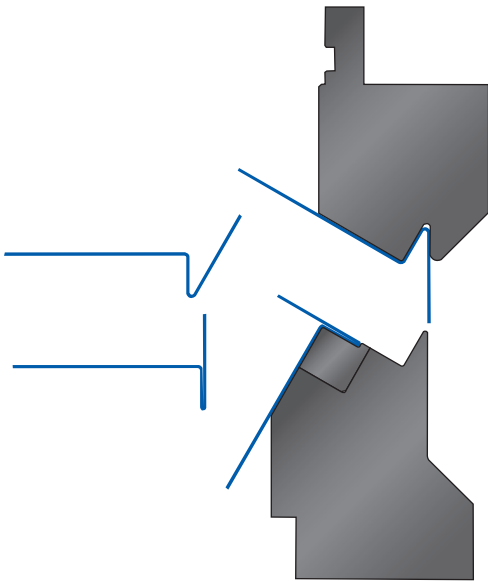

AH1 — ANGLE HEM

Typically used to form seams in excess of 1/2 inch.

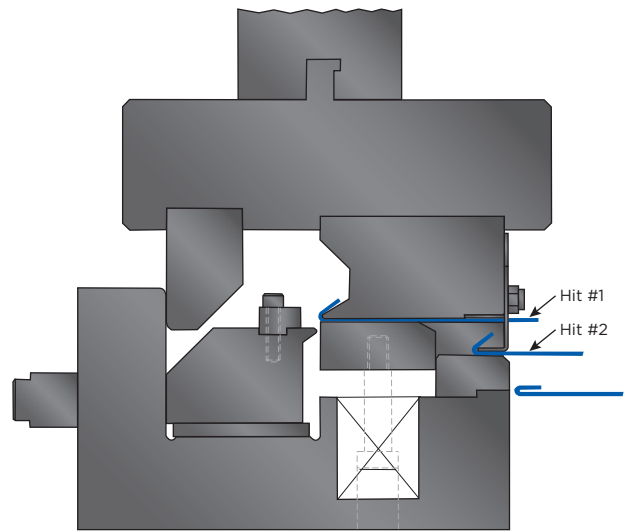

FSH1 — FLAT SHEET HEM

SPECIALS

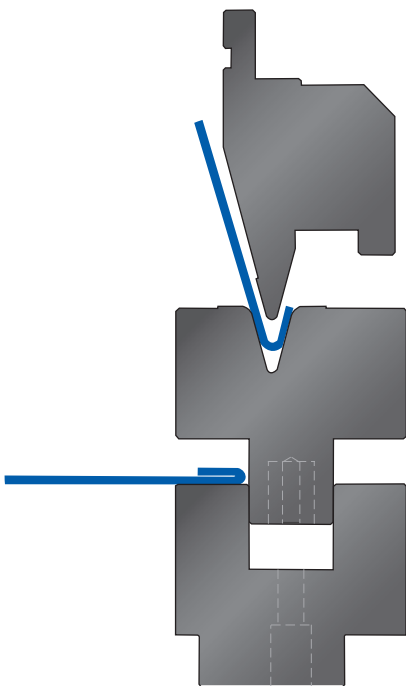

HDH1 — HEAVY DUTY HEM

Heavy duty hemming for thick gauge applications.

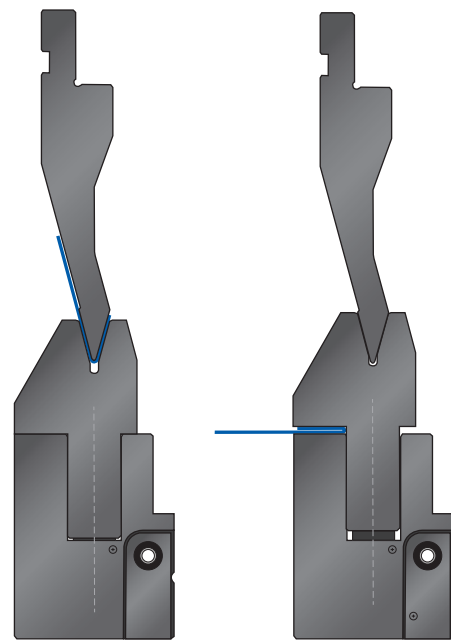

PH1 — PNEUMATIC HEM

This tool set introduces pneumatic cylinders to rapidly open and close the pre-form insert. This set removes the inconsistency associated with pre-forming or acute bending on a spring actuated insert.

CUSTOM HEMMING

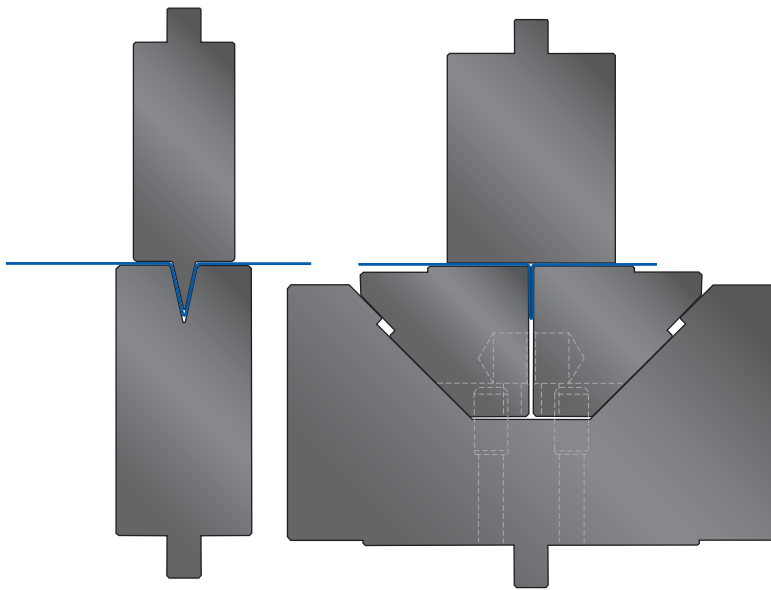

SH1 – SEAM HEM
Two tool sets. Two machine strokes

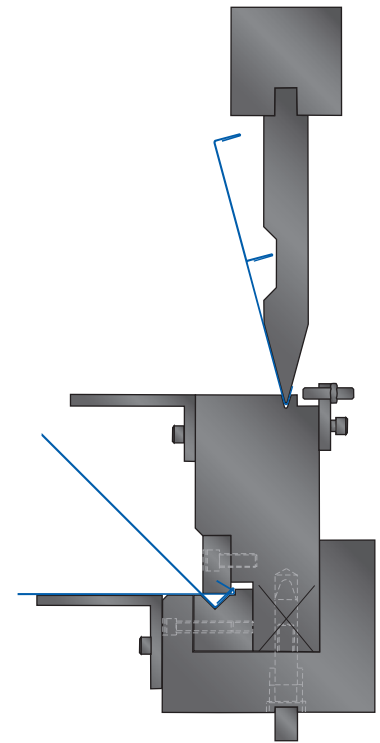

SSH2 – STANDING SEAM HEM

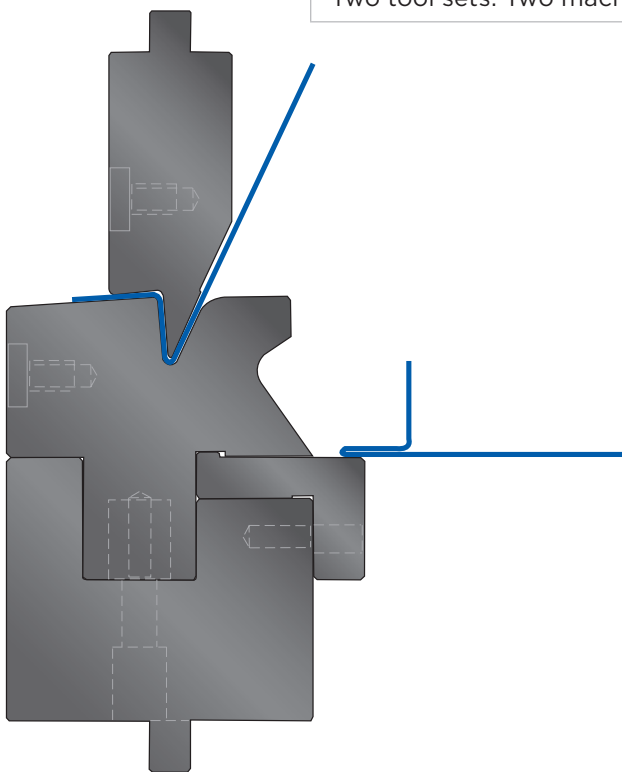

SSH1 – STANDING SEAM HEM
Used to form a standing seam in two strokes. The first stroke forms an acute angle offset, the second stroke closes the seam.

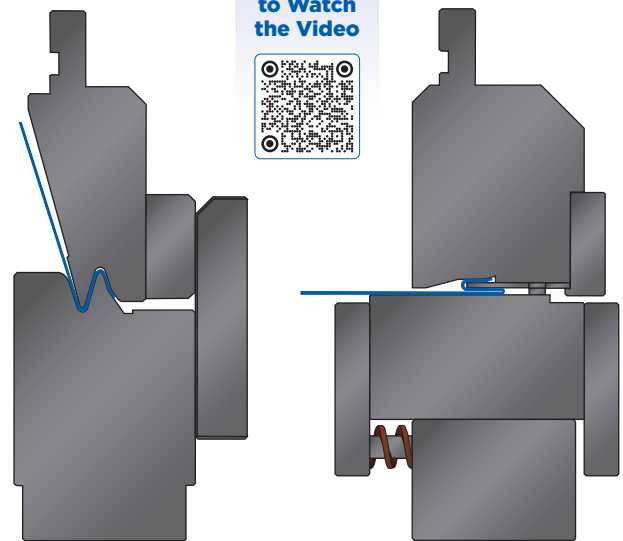

ZH1 – Z HEM
Creates a Z-hem or a Clip hem. Shim can be built in to maintain a gap in the hem. Two tool sets. Two machine strokes.

SPECIALS

OFFSET TOOLS

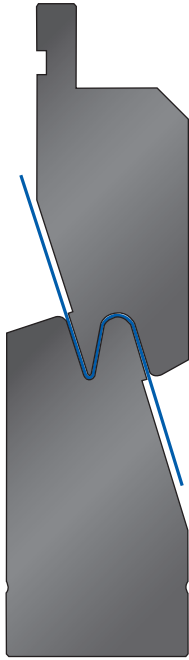

AO1 – ANGLED OFFSET

Scan
QR Code
to Watch
the Video

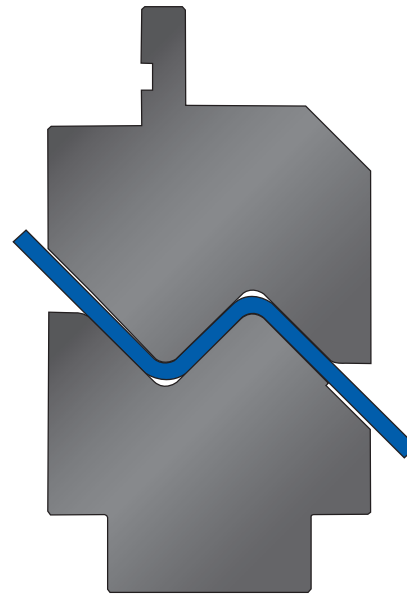

LO1 – LARGE OFFSET

Used for heavy gauge,
large offset bending.

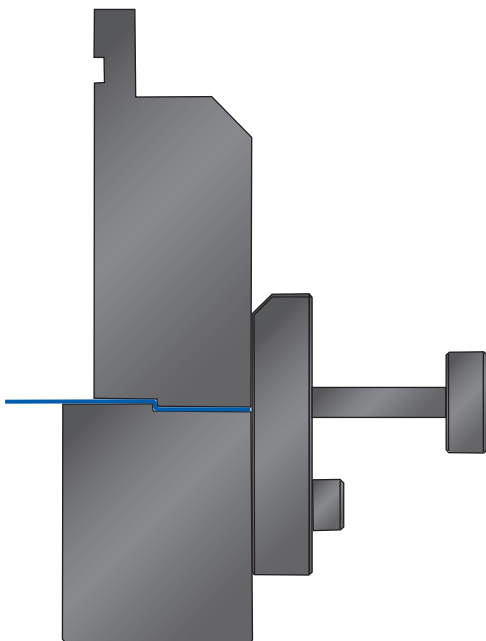

HO1 – HORIZONTAL OFFSET

For offsets that are approximately
one material thickness. Prevents
material whip up. Thrust plates and
adjustable back gauging are provided.

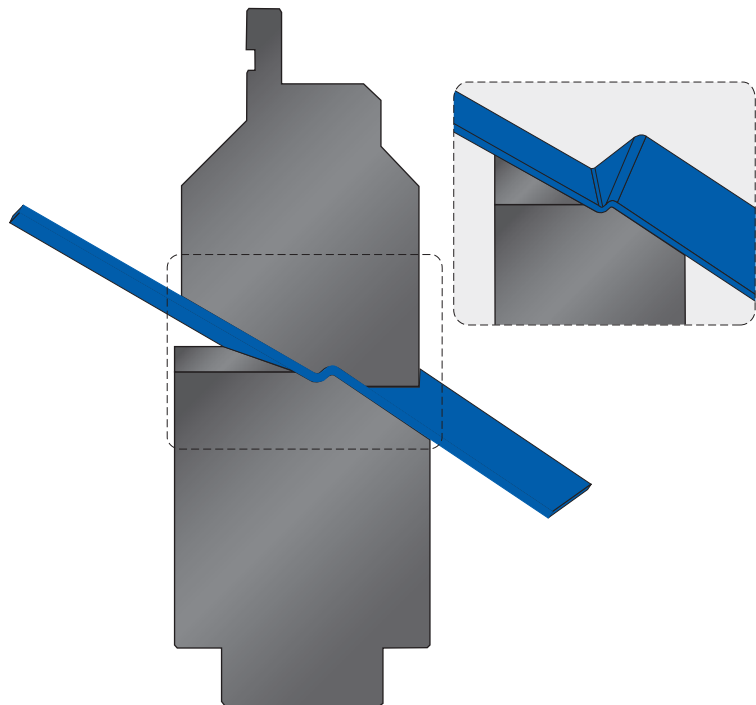

NPO1 – NON PARALLEL OFFSET

For offsets that have non-parallel flanges. Inset shows
punch hidden for a clear view of the formed sheet.

ADJUSTABLE DIES

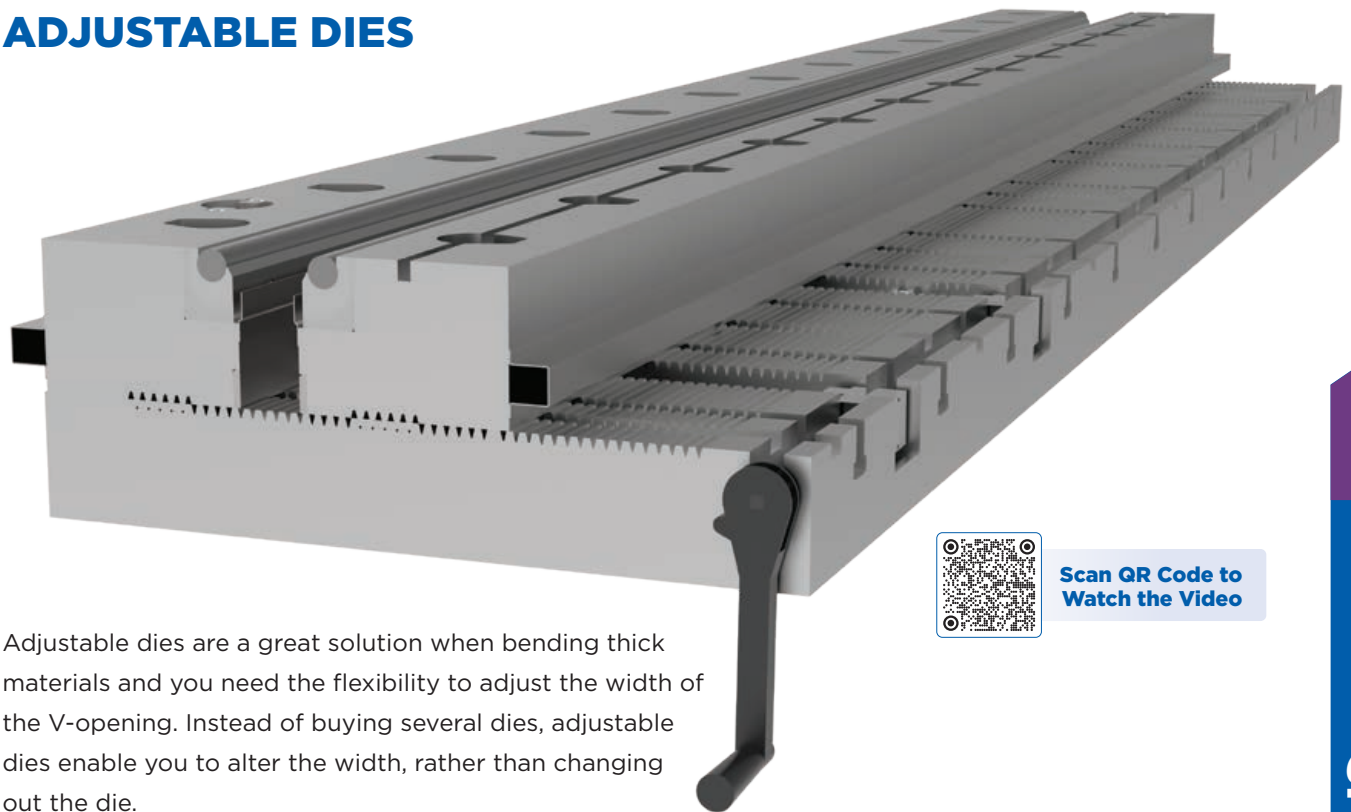

Scan QR Code to Watch the Video

Adjustable dies are a great solution when bending thick materials and you need the flexibility to adjust the width of the V-opening. Instead of buying several dies, adjustable dies enable you to alter the width, rather than changing out the die.

Adjustable Die Features

- Riding on spring-loaded ball bearings, openings are easily adjusted by one operator
- Available openings range from 1 to 24 inches and can be adjusted in 1-inch increments
- Capable of withstanding tonnage of up to 400 tons per foot, allowing easy thick material bending
- Induction hardened and hard chrome rollers help reduce required tonnage by as much as 20%
- Chrome rollers can be replaced at your facility

Die Holder Slots

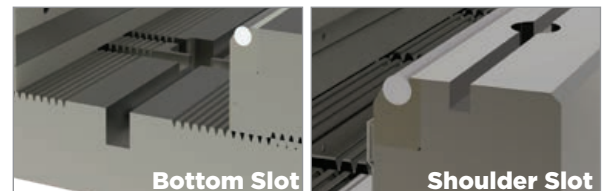

Adjustable Die Options

- Die assembly can be configured to remain on the press permanently and function as a standard die holder
- Cover bellows are available to keep the grooves that are used to adjust the dies free from dirt and dust
- Available clamping options for side blocks include manual and automated release and/or movement
- Available with Manual, Ball Screw, Hydraulic and CNC options

Opening Adjustments

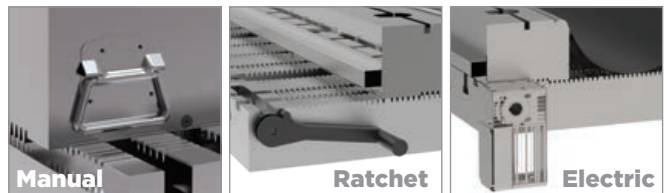

Shoulder Inserts



REPLACEABLE SHOULDER DIES

Dies that have a replaceable shoulder radius are ideal for extreme wear conditions like heavy plate and abrasive materials. Replacing the shoulder insert saves on replacement cost.

Since the radius is able to rotate during bending, friction and tonnage are reduced, resulting in reduced part marking and less tonnage on tooling and machinery.



Scan QR Code for More Thick Material Solutions

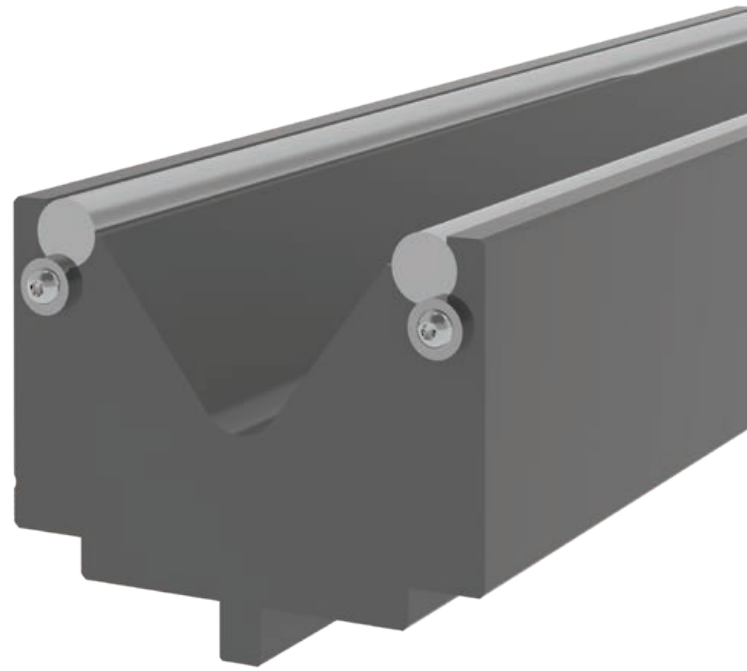

DOVETAIL HOLDER AND RADIUS

Lighten Your Load with Two-Piece Punches

Replaceable radius punches help limit tooling costs, reduce setup time and lighten tool changes. Tip inserts simply slide on and off the universal punch body, increasing the flexibility of each punch and minimizing heavy lifting for the operator.

Replaceable Radius Punch Highlights

- Setup is as simple as sliding the tip insert on and off the tool body
- No adjustment is required between punch radius changes
- Tip is lighter than a standard punch for easier tool changes
- Lighter tools reduces need for multiple operators
- Lighter tools creates a safer handling environment for operators
- Tool costs are minimized when purchasing one body with multiple tips
- Various angles and radii can be loaded into the same punch holder

Details

- Made to suit specific needs
- Designed to tackle light- or heavy-duty bending
- Ground and induction hardened for optimal life and performance
- Dovetail or T Style attachment feature



Dovetail

T Style



Scan QR Code to Watch the Video



LARGE RADII

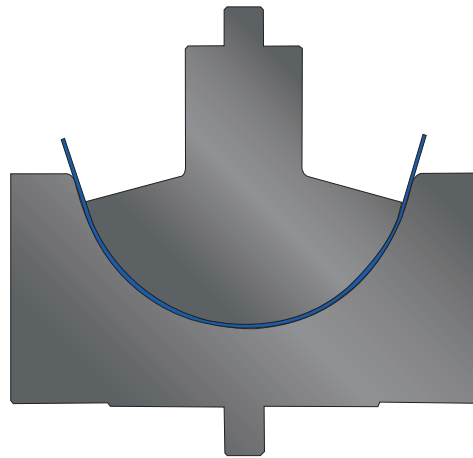

Scan QR Code to Watch the Video



LR1 – LARGE RADIUS

Bottoming radius set with spring-back allowance built in. It is manufactured to form a radius in a specific type and thickness of material for tight tolerance requirements.

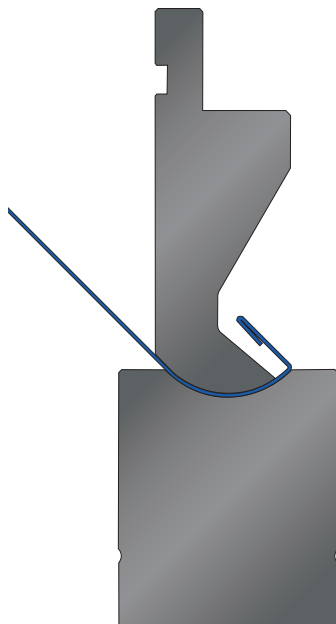

LR2 – MULTI-HIT RADIUS

Used when a full radius is required before the flange. The solution may require multiple strokes.

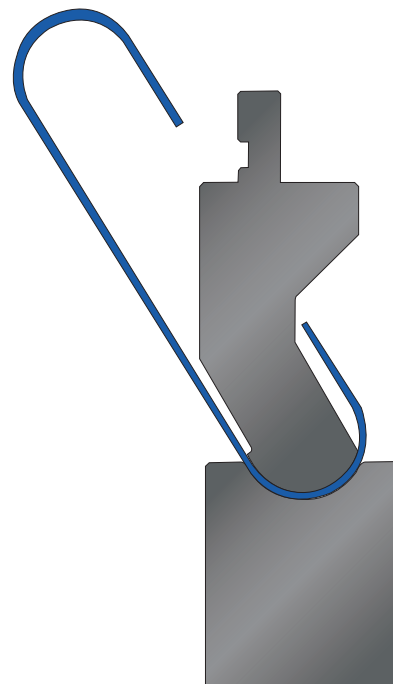

LR3 – MULTI-HIT RADIUS

Used when the return flange starts at the radius end. The solution may require multiple strokes.

STRENGTHENING RIB

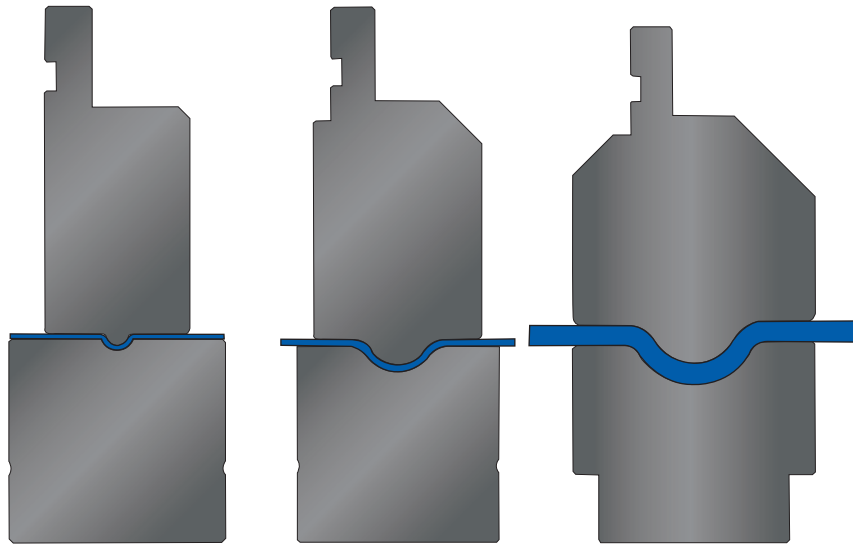

Scan
QR Code
to Watch
the Video



SR1 — STRENGTHENING RIB

Produce a strengthening rib in one stroke. Spring back allowance is built in. Closed end and open end ribs are available.

V-RIB

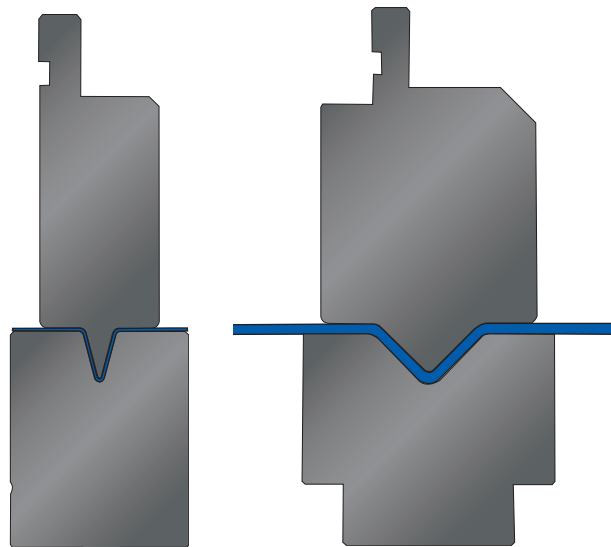

VR1 — V RIB

Produce a V rib in one stroke.
Spring back allowance is built in.



FORMING

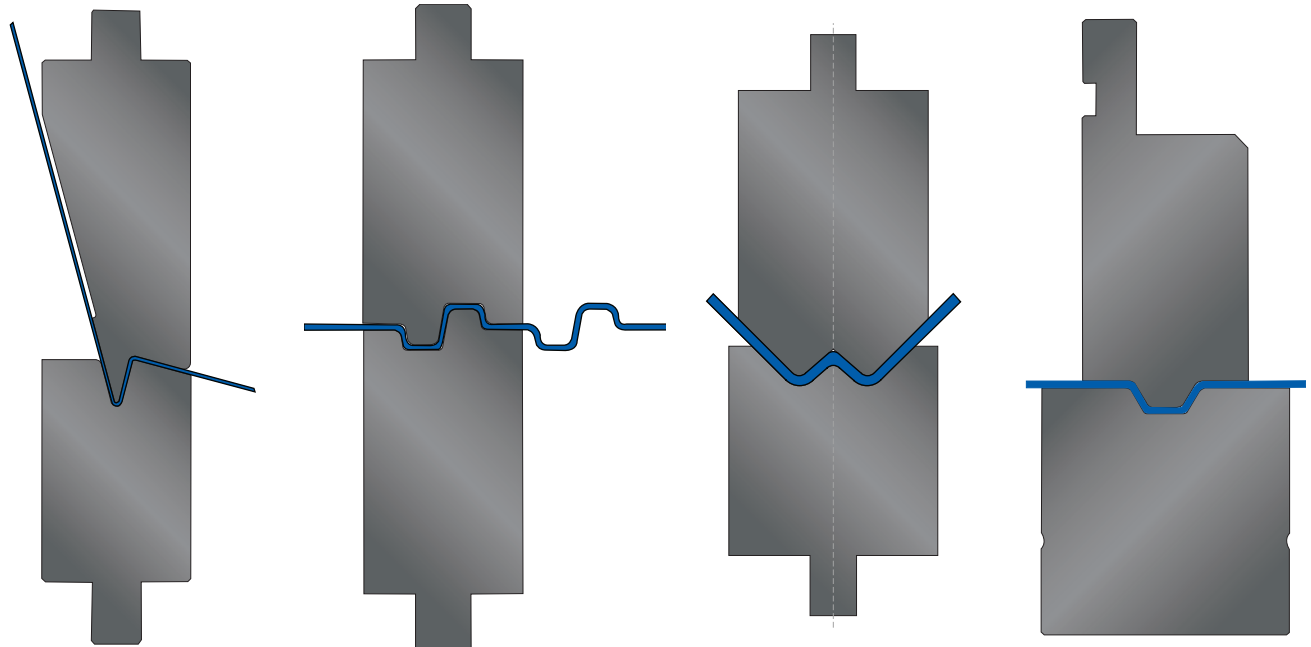

FM1 — FORMING

FM2 — FORMING

FM3 — FORMING

OH1 — OPEN HAT

A large variety of custom forming sets are available. Custom built to suit any specific requirement. Call for specific application requirements.

SPECIALS

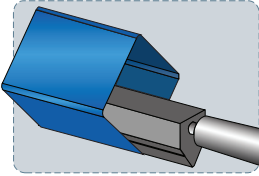
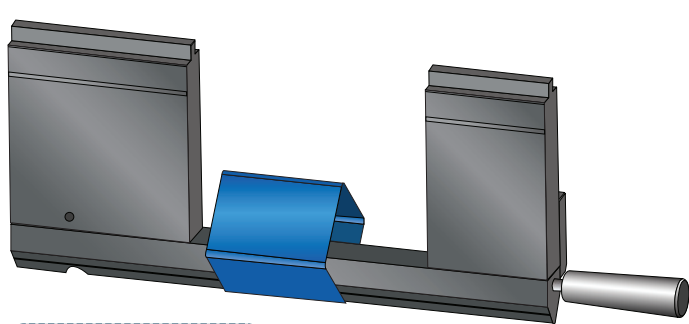

Scan QR Code to Watch the Video

W1 — WINDOW
Used when minimum return flange clearance is required.

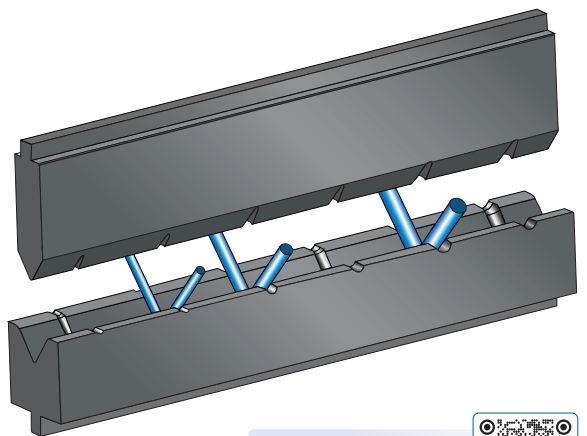

Scan QR Code to Watch the Video

RB1 — ROD BENDING
Provides nesting for the rod during the forming process.

STAMPING

SPECIALS

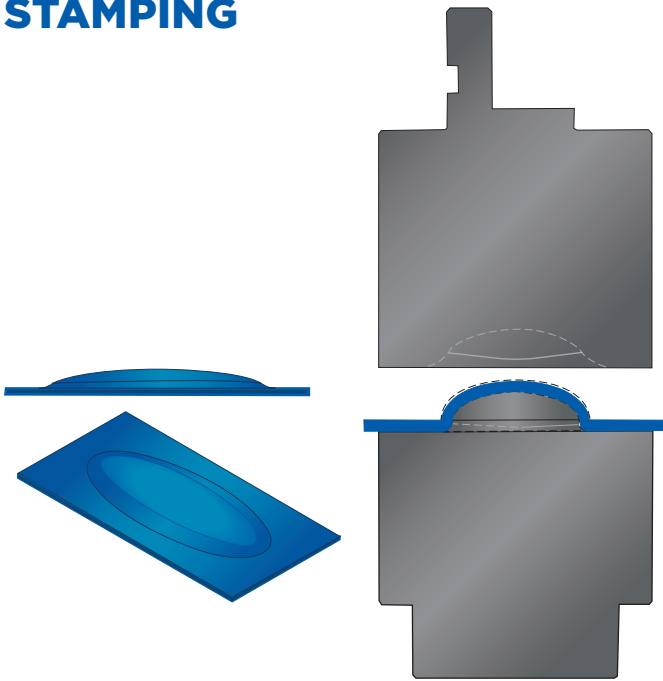

EM1 – EMOSS

A variety of raised emboss and chisel point emboss sets are available.

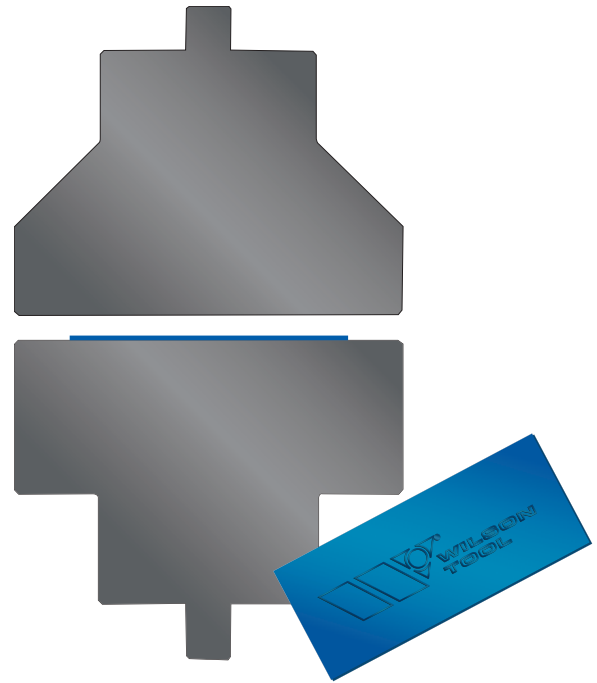

LG1 – LOGO

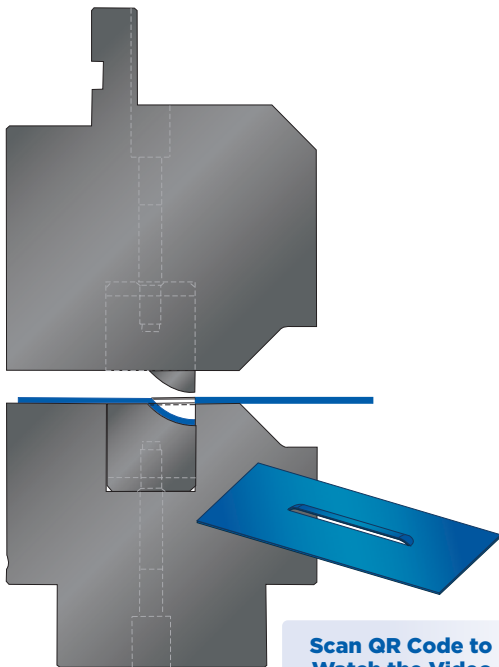

LL1 – LOUVER

Multiple louver configurations are available. For louver forming, sheet must be pre-slit.

Scan QR Code to Watch the Video

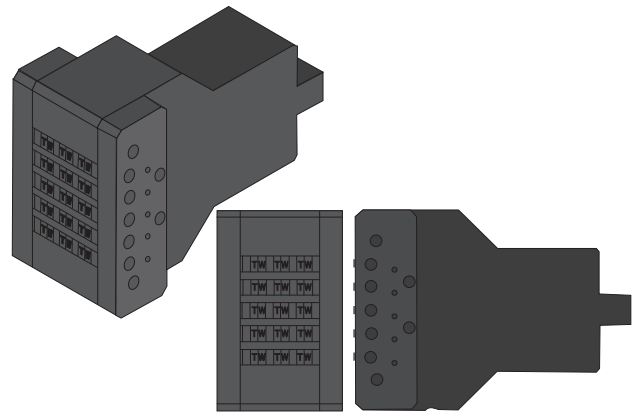

LS1 – LETTER STAMP

Provides chisel point embossing with interchangeable characters. Single row or multi-row available.

Part No.	Description	Size	Price
6LSP25	Punch Character Holder	3.75" Staged	
65300003-500	Flattening Block Die	—	
6898	Character	3/32"	
6896	Character	1/8"	



MECHANICAL

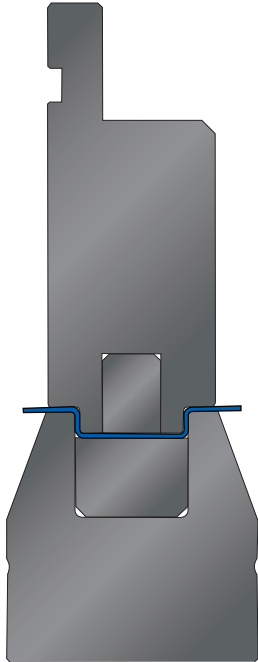

HT1 – HAT CHANNEL

Provides straight wall or angled wall hat channel bending in one stroke. Spring back allowance built in.

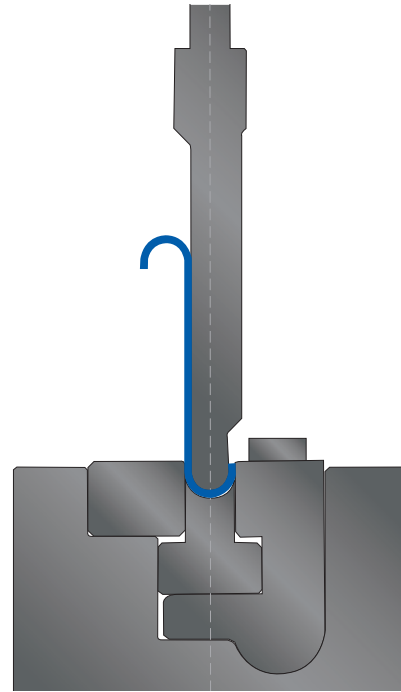

UC1 – U CHANNEL

Recommended for applications where considerable spring back is encountered. Secondary flattening operations may be required.

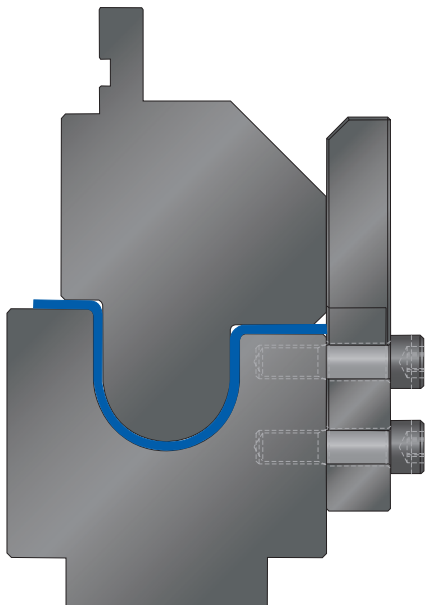

UC2 – U CHANNEL

Recommended for applications where considerable spring back is encountered. Secondary flattening operations may be required.

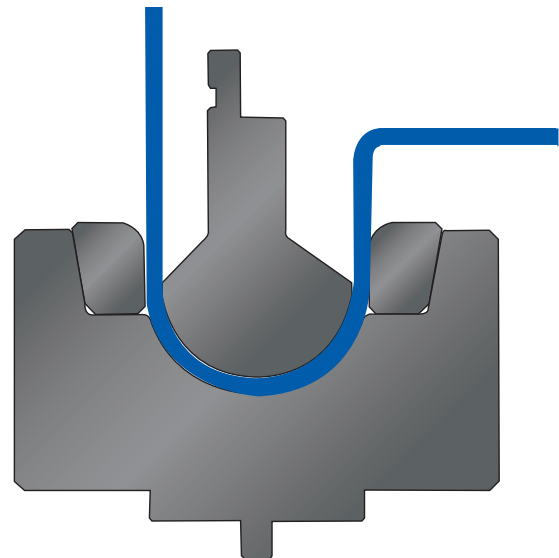

UC3 – U CHANNEL

Recommended for applications where considerable spring back is encountered. Secondary flattening operations may be required.

MECHANICAL

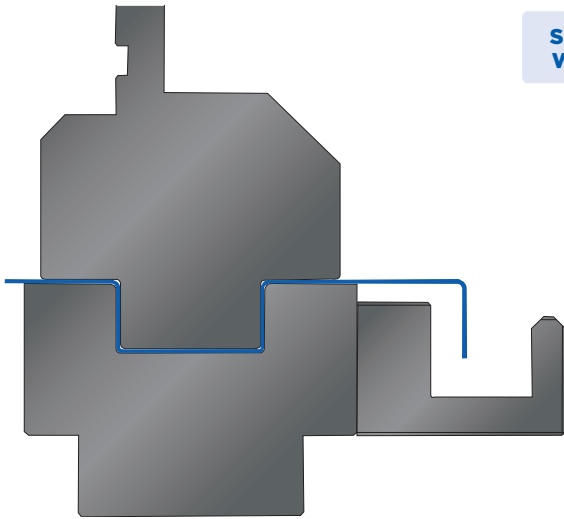

C1 – CHANNEL

For deep channels when the channel bottom needs to remain flat.

Scan QR Code to Watch the Video

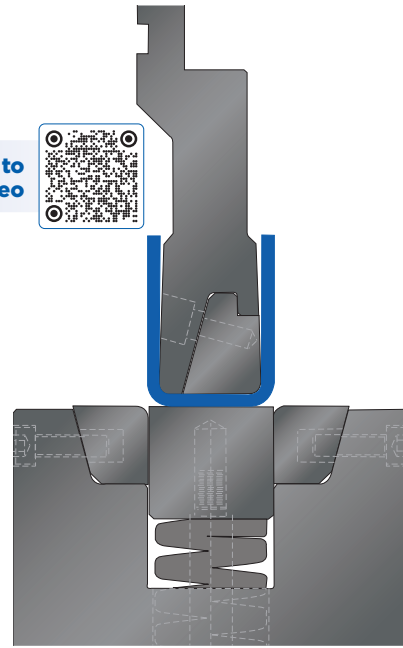

C2 – CHANNEL

For deep channels when the channel bottom needs to remain flat.

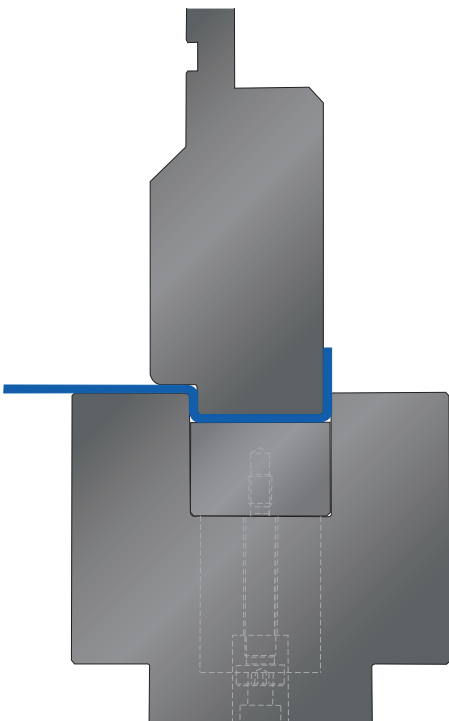

C3 – CHANNEL

For deep channels when the channel bottom needs to remain flat.

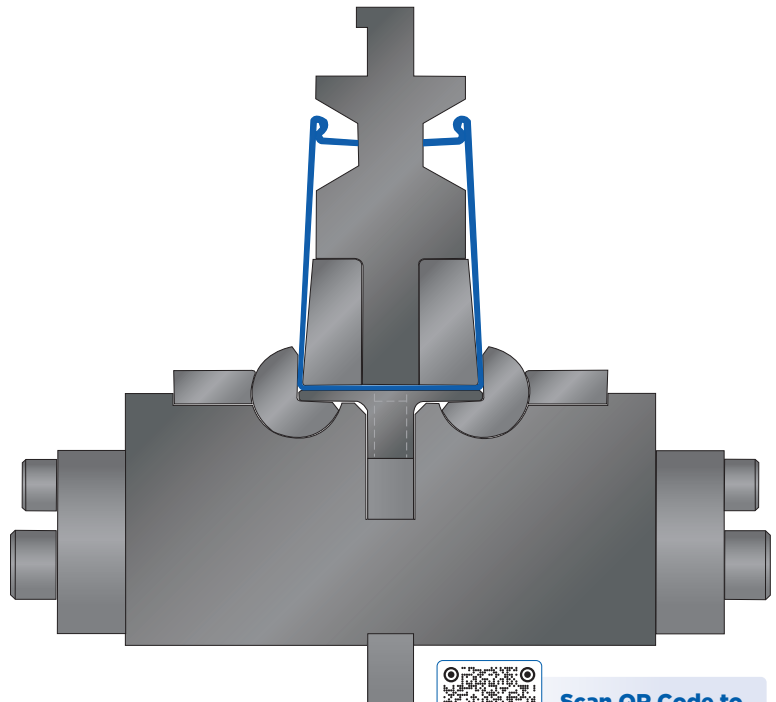

C4 – ROTARY BEND CHANNEL

For deep channels when the channel bottom needs to remain flat.



Scan QR Code to Watch the Video



MECHANICAL

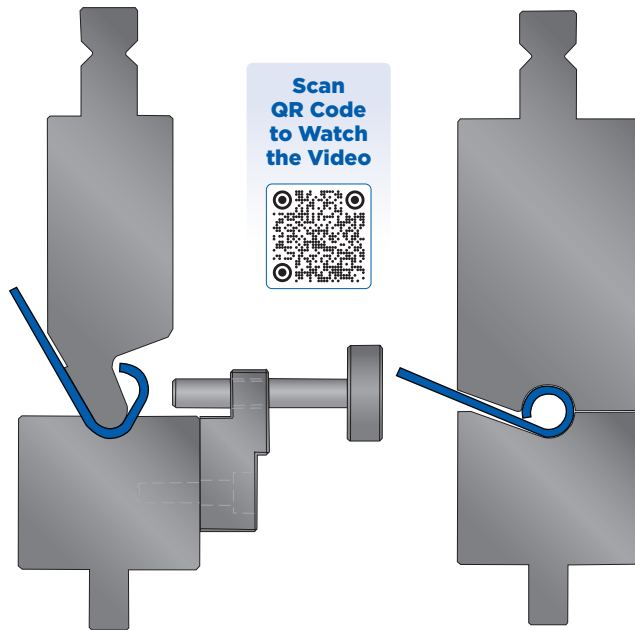

CL1 – CURL TOOL SET

Two tool sets, three machine strokes.

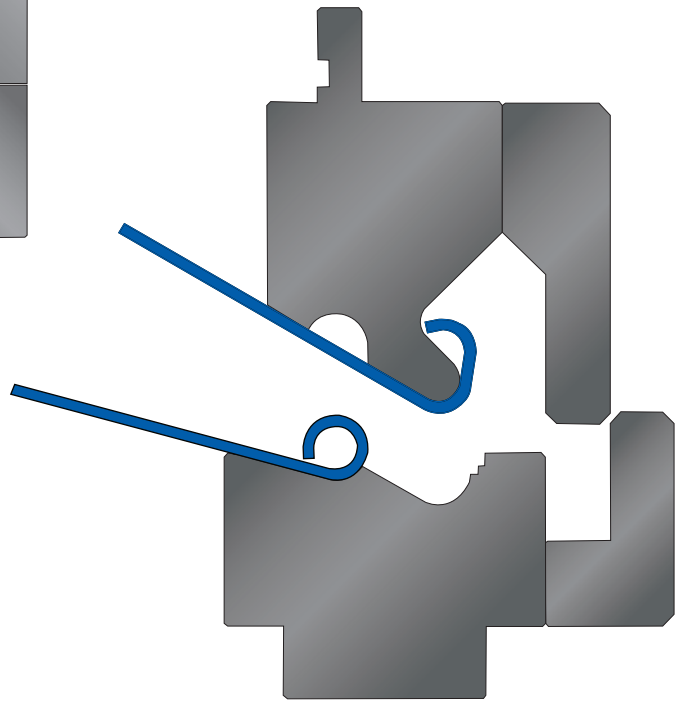

CL2 – CURL TOOL SET

Typically used for thick materials and large diameter curls.
One tool set, three machine strokes.

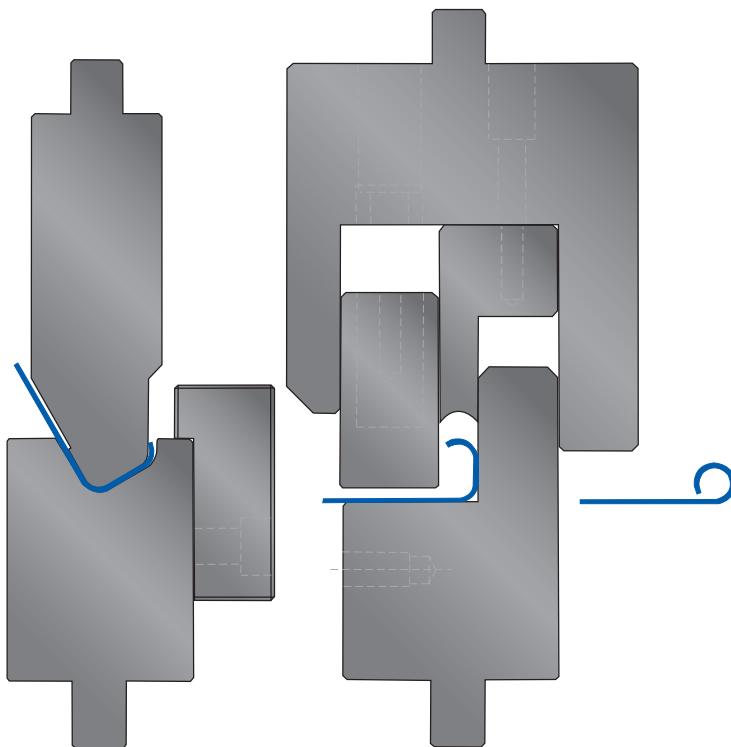

CL3 – CURL

Used for hinges and corner beading.
Two tool sets, two machine strokes.

SPECIALS

MECHANICAL

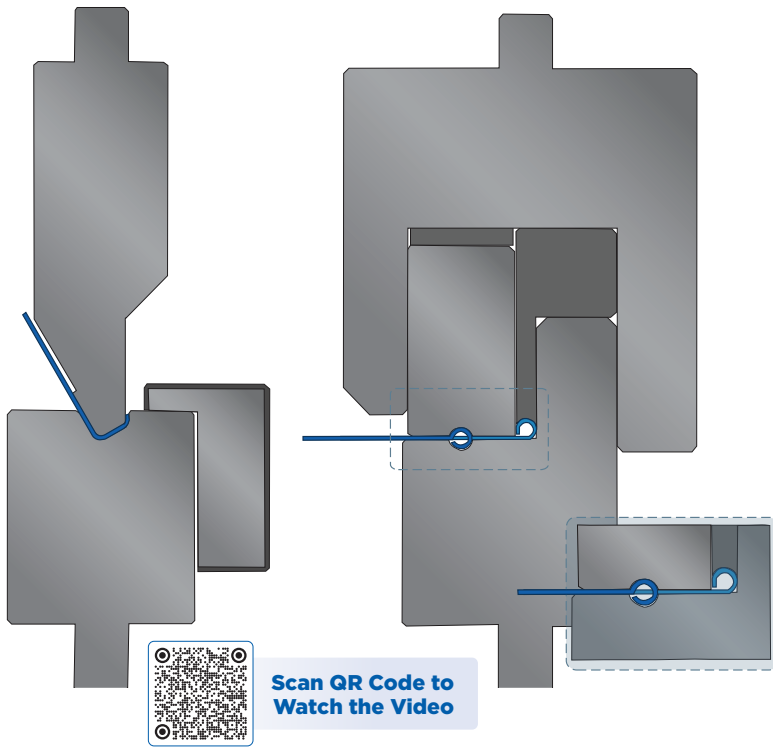

Scan QR Code to
Watch the Video

CL4 – CENTER CURL APPLICATION

Two tool sets, three machine strokes.

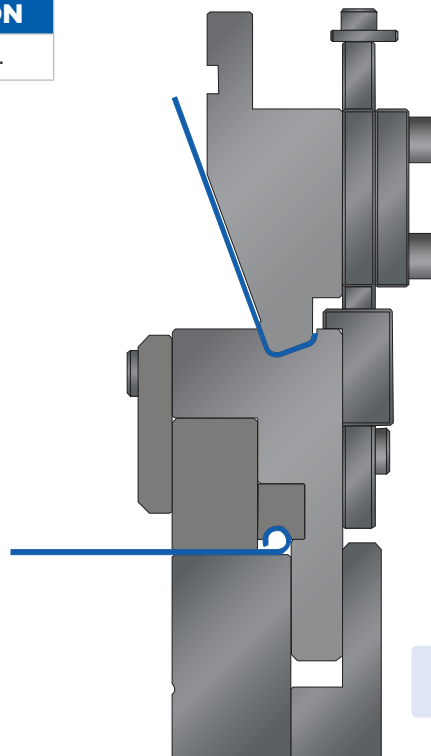

Scan QR Code to
Watch the Video

CL5 – DOUBLE DECKER TOOL SET

Used for hinges and corner beading.
One tool set, two machine strokes.



SPECIAL SHAPE PUNCHES

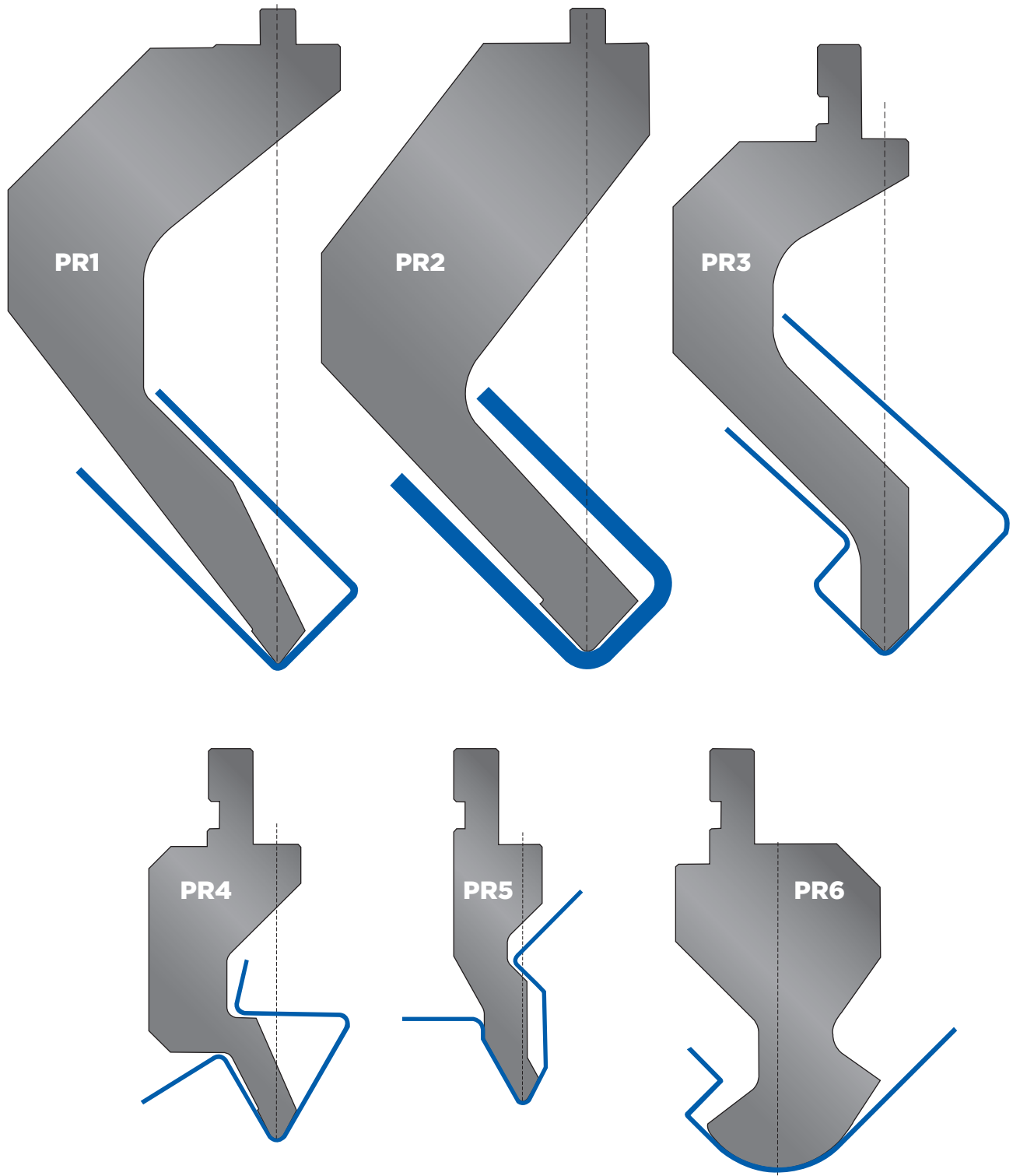

SPECIALS

PUNCH HOLDERS



WT – AMERICAN

With Set Screws



AMERICAN SELF-SEAT HOLDER

WT to American with Clamp Plate

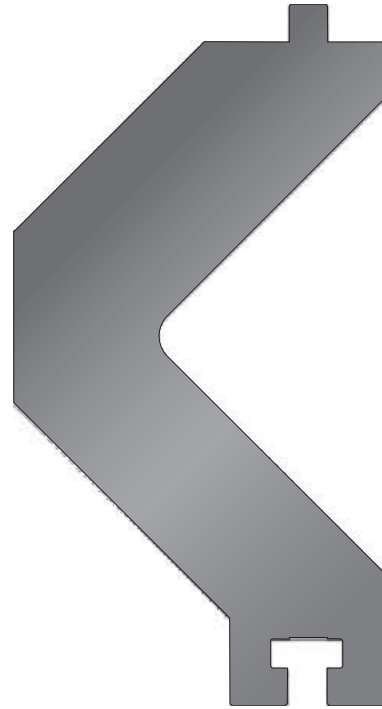

**AMERICAN DEEP
GOOSENECK HOLDER**

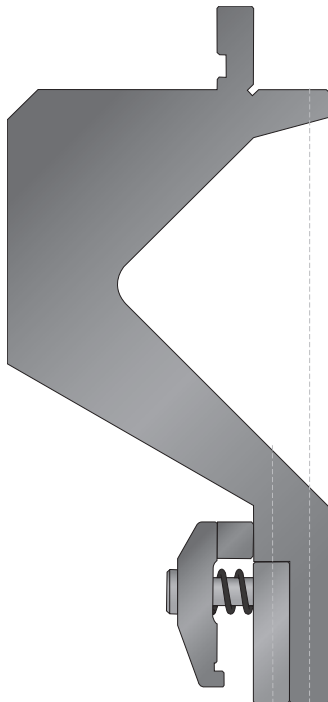

EURO Z1 OR Z2 CLAMPING

Part No. 43002

PUNCH HOLDERS

Stack punch holders to make a taller punch to bend tall side flanges or to replace worn OEM punch holders that need replacement. These holders can be made in small sections or one piece to fit the length of your brake.

PUNCH HOLDERS

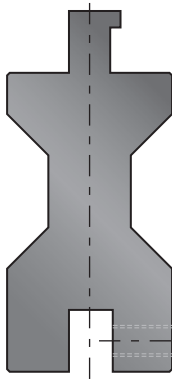

RA1 — DOG BONE

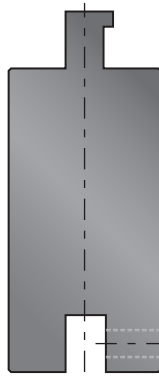

RA2 — SET SCREW

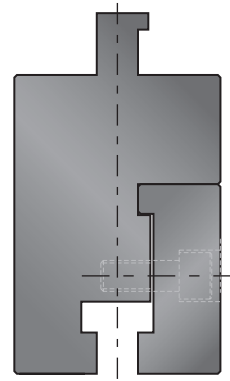

RA3 — CLAMP PLATE

Holders are commonly made to replace any original OEM punch and/or die holders or to accommodate part configuration. These designs can be one solid length or sections that are easier to handle.

DIE HOLDERS

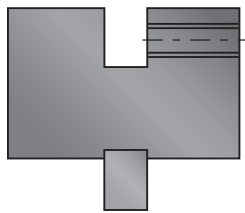

DIE HOLDERS

Die holders can raise the die to help with down flange interference or to replace worn OEM die holders that need replacement. These holders can be made in small sections or one piece to fit the length of your brake.

WIPING AND ROTARY BENDING

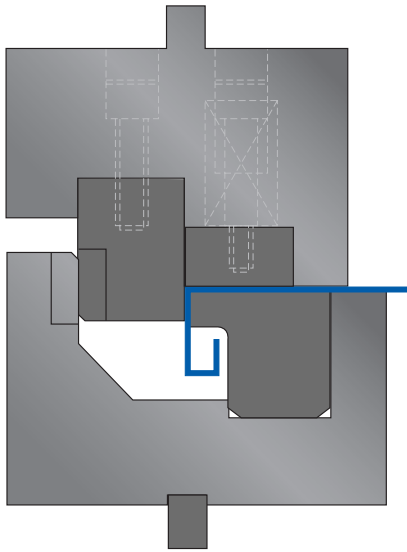

Scan QR Code to Watch the Video

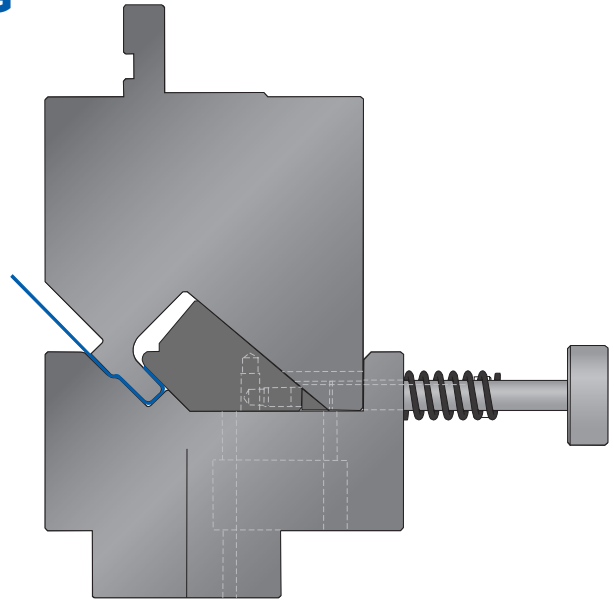

WD1 – WIPE DOWN

Holds the sheet flat while wiping the flange down. Ideal for large panels and high production.

WO1 – WIPING FORM

Holds the sheet flat while wiping the flange down. Ideal for large panels and high production.

SPECIALS

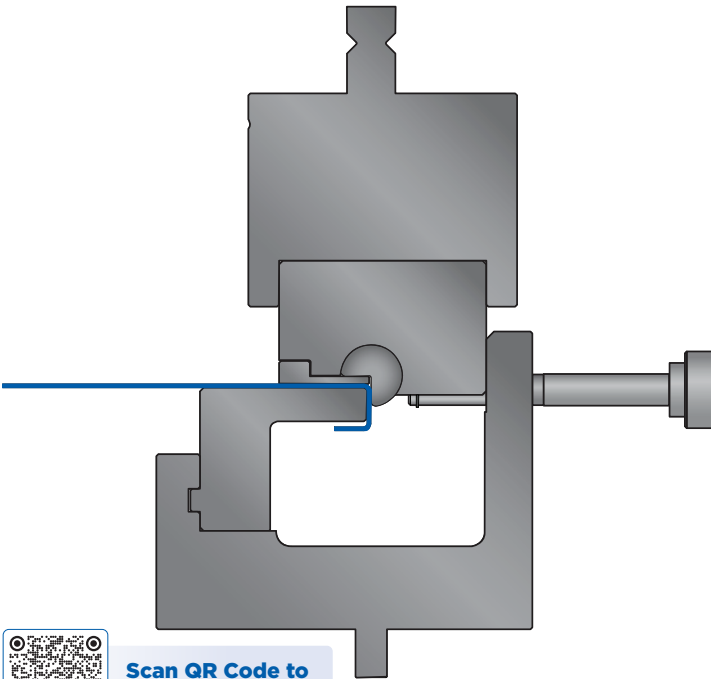

Scan QR Code to Watch the Video

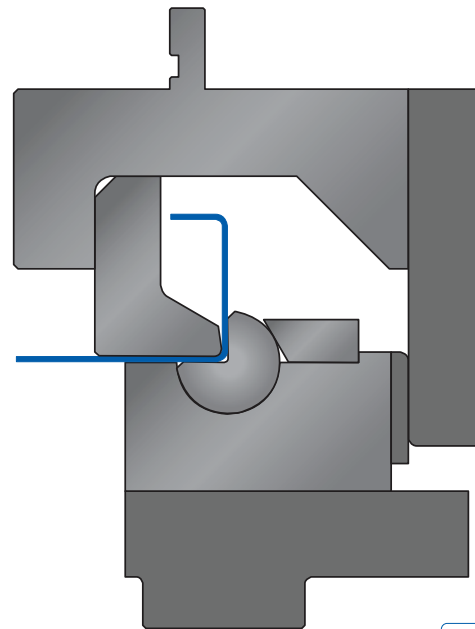

Scan QR Code to Watch the Video



RTD – FORM DOWN

RTU – FORM UP

ROTARY FLANGE FORMING

Holds sheet flat while forming. Overbend allowance is built in to compensate for material springback. Ideal for large panels and high production.



30/60 DEEP BOX BENDING

When forming a 4-sided box, the punch must be sufficient height to prevent the pre-formed side from striking the upper beam. This is a thrusting application and not suitable for all press brakes.

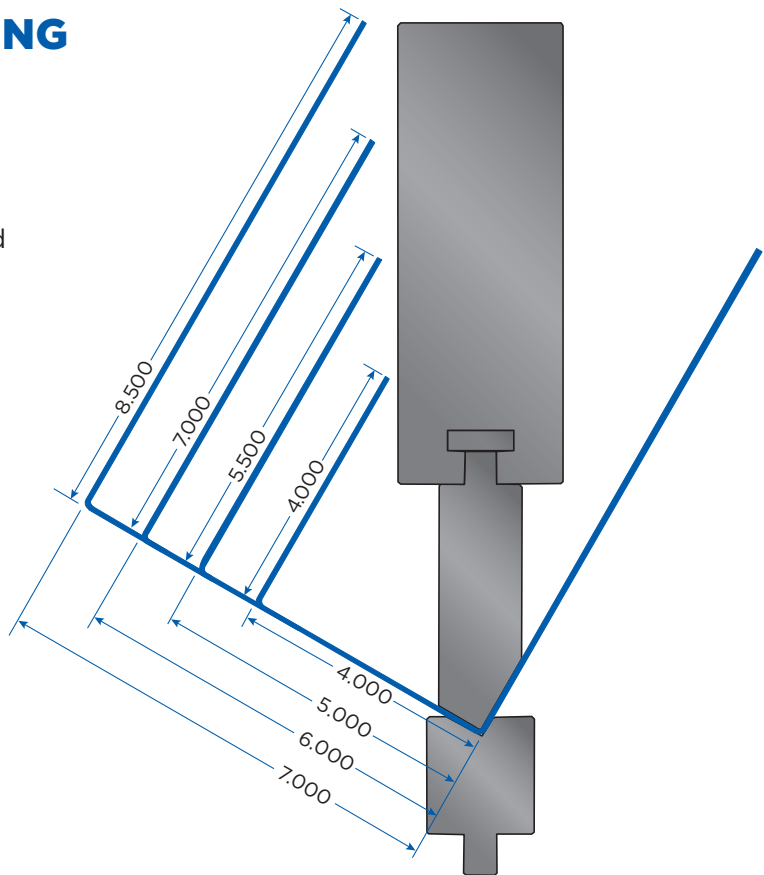

SWING EAR SECTIONS

- Box bending with return flanges.
- Standard bend length 150mm each ear on all punch profiles. 100mm length available on select profiles.
- Ear(s) recess/fall in left to right .50 - .75", not to be confused with vertical movement. There will be approximately 1.0 - 1.5" of relief to rotate and drop the finished part.
- Punch profile will match the standard profile only in height, angle and radius. Width will be wider where hinged.



Scan QR Code to Watch the Video



Left and right ear sections shown in illustration.

UNITIZED TOOLING

Unitized tooling offers flexibility for various applications, including press brakes, Multicyl setups, and presses. For press brakes, simply attach the units to a bed rail or use a job-specific template. These templates function as a plug-and-play system: attach the template to the machine, secure it and begin punching parts. Once finished, remove the entire plate, including the mounted units. To reduce weight, the plates can be segmented.

Bed rails with adjustable spacers allow you to easily reposition units to accommodate various specifications. Sliding on the face of the bed rails, combined with universal stops on the sides and back, ensure accurate and consistent placement of extruded or flat sheets. This flexibility enables repeatable production processes.



Scan QR Code to
View the Catalog

Tooling shown below mounted on a bed rail.

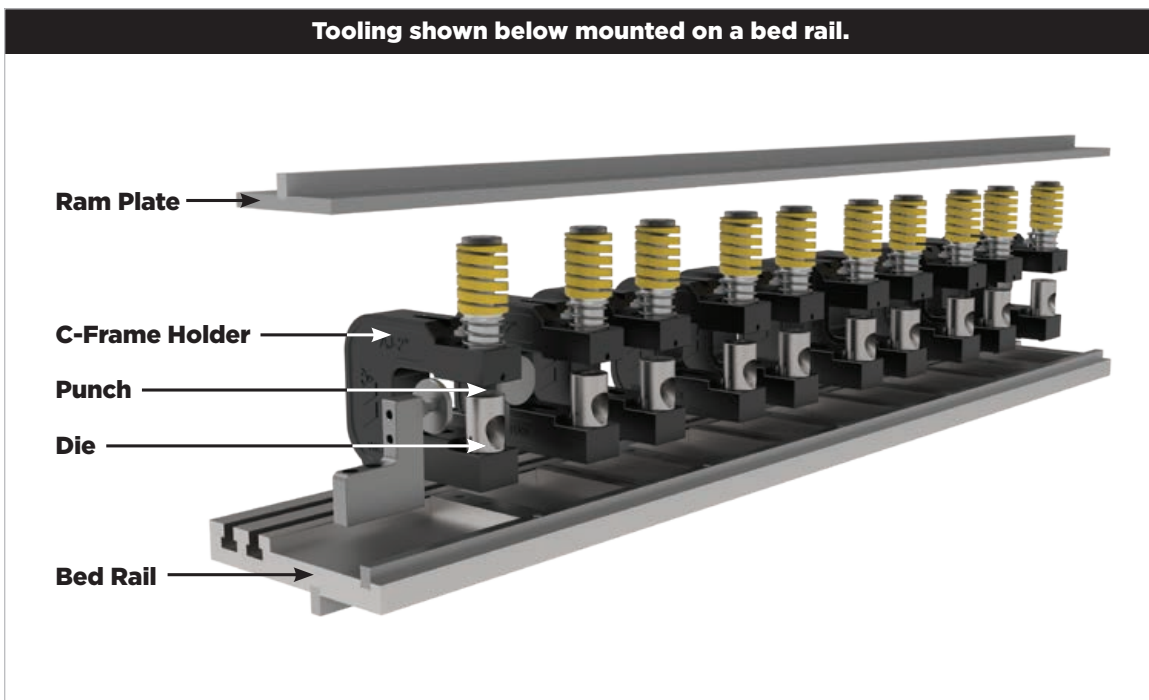

AIR BENDING FORCE CHART IMPERIAL V-OPENINGS & IMPERIAL TONNAGE

NOTE: Formulas and chart are for reference only.

T = Material Thickness; V = V-Opening; MF = Minimum Flange Length; IR = Inside Radius

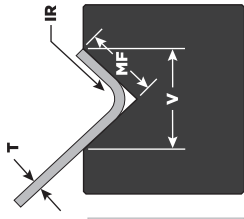

STANDARD FORMULAS FOR SELECTING A V-OPENING

Material Thickness: .105" or Less = $T \times 6$
 .120" - .313" = $T \times 8$
 .375" - .500" = $T \times 10$
 .625" & Thicker = $T \times 12$

GAUGE	DEC. inch [mm]	TONS PER FOOT																	
		V (in.)	0.250	0.313	0.375	0.500	0.625	0.750	0.875	1.000	1.125	1.250	1.500	2.000	2.500	3.000	3.500	4.000	5.000
	MF	0.180	0.225	0.270	0.360	0.450	0.540	0.630	0.720	0.810	0.900	1.080	1.440	1.800	2.159	2.519	2.879	3.599	
	IR	0.042	0.052	0.063	0.084	0.104	0.125	0.146	0.167	0.188	0.209	0.251	0.334	0.418	0.501	0.585	0.668	0.835	
20	0.036 [0.9]	2.9	2.2	1.7	1.2	1.0													
18	0.048 [1.2]	7.0	4.0	2.9	2.2	1.6	1.3												
16	0.060 [1.5]		7.8	5.6	3.6	2.7	2.2	1.7											
14	0.075 [1.9]			11.7	6.0	4.5	3.4	3.0	2.5	2.1									
13	0.090 [2.3]				12.2	6.8	5.4	4.3	3.7	3.3	2.9								
12	0.105 [2.7]					10.1	7.4	6.3	5.4	4.4	4.0	3.2							
11	0.120 [3]						10.5	8.8	7.2	6.2	5.4	4.3	3.2						
10	0.135 [3.4]							11.3	9.6	8.4	7.0	5.6	4.1						
9	0.150 [3.8]								13.1	11.9	9.0	6.7	5.2	3.5					
7	0.188 [4.8]									16.4	14.0	11.2	7.6	5.8	4.5				
1/4"	0.250 [6.35]										28.8	22.0	15.3	11.5	9.1	7.5	6.2		
5/16"	0.312 [8]											38.0	26.0	19.2	16.0	12.5	10.6	7.6	
3/8"	0.375 [9.5]												41.0	29.9	24.0	19.4	16.0	12.3	
7/16"	0.438 [11.1]													45.2	35.0	28.0	24.0	17.0	
1/2"	0.500 [12.7]														47.9	39.0	33.1	24.0	
5/8"	0.625 [16]															69.5	58.0	42.2	
3/4"	0.750 [19]																92.0	69.0	
7/8"	0.875 [22]																	104.0	
1"	1.000 [25.4]																		

Larger v-openings generate less tonnage.

Smaller v-openings generate increased tonnage and are NOT recommended.

Tonnage Estimation Based on Material Type
Soft Aluminum, Brass, Copper = Tons x 0.35
Half Hard Aluminum = Tons x 0.5
Hard/Heat Treated AL, Mild Steel = Tons x 1.0
Half Hard Brass, Copper = Tons x 1.1
Stainless Steel = Tons x 1.5
High Strength Steel = Tons x 2.75

Scan QR Code to Watch the Video

NOTE: The chart above is based on mild steel (tensile strength of 60,000 PSI) formed to an included angle of 98°. See chart to the right for other materials. Forming to other angles will change the Minimum Flange (MF), Inside Radius (IR) and tonnage.

















TONNAGE ESTIMATES

Making Multiple Bends Formula on a Press Brake

For shape as shown, in mild steel with radii equal to the metal thickness unless otherwise noted.

MULTIPLY METAL THICKNESS BY FACTOR = TONS PER FT.

SHAPE	DESCRIPTION	AIRFORM	BOTTOMING
	VEE DIE	60	150
	WIPING	–	250
	OFFSET	150	300/600
	MATERIAL THICK OFFSET	300	600
	CHANNEL	300	600
	VEE RIB	200	600
	W DIE	300	600
	OPEN HAT CHANNEL	300	450
	SQUARE HAT CHANNEL	–	600
	PREFORM CURL	–	300
	PREFORM CURL	–	200
	CLOSED CURL	–	300
	RADIUS	–	180/300
	(AIR) TEAR DROP	–	200
	CRUSHED HEM	–	400
SHAPE CONSIDERATIONS		Large Radii Angle Variation Concave/Convex sides	Material Thick Radii Min. Angle Variation Maintain Flatness

REFERENCE

Tonnage Estimation Based on Material Type	Soft Aluminum, Brass, Copper = Tons x 0.35
	Half Hard Aluminum = Tons x 0.5
	Hard/Heat Treated AL, Mild Steel = Tons x 1.0
	Half Hard Brass, Copper = Tons x 1.1
	Stainless Steel = Tons x 1.5
	High Strength Steel = Tons x 2.75

PRESS BRAKE SPECIALS CHECKLIST

Company:	
Contact:	
Phone:	Sales Engineer:
Quote #:	Sales Desk Contact:

MACHINE SPECIFICATIONS

BRAKE MAKE/MODEL		TONNAGE	
OVERALL LENGTH		APPROX. AGE	
STROKE	<i>Open Height</i>		<i>Closed Height</i>

TOOLING AND APPLICATION

TOOLING TYPE	<input type="checkbox"/> American <input type="checkbox"/> European <input type="checkbox"/> WT <input type="checkbox"/> Bystronic <input type="checkbox"/> Other			
LENGTH OF BEND				
MATERIAL TYPE		THICKNESS		
Is customer currently performing this bend? <input type="checkbox"/> Yes <input type="checkbox"/> No If YES, specify if this is a <input type="checkbox"/> Wilson Tool Repeat <input type="checkbox"/> Replicate Customer Tool <input type="checkbox"/> Redesign				
Explain:				

TOLERANCE BLOCK

PART RADII TOLERANCE	<i>Tolerances tighter than $\pm 5\%$ may affect price/lead time</i>
PART BEND ANGLE TOLERANCE	<i>Tolerances tighter than $\pm 3\%$ may affect price/lead time.</i>
ESTIMATED ANNUAL USAGE	



TYPICAL PRESS SETUP

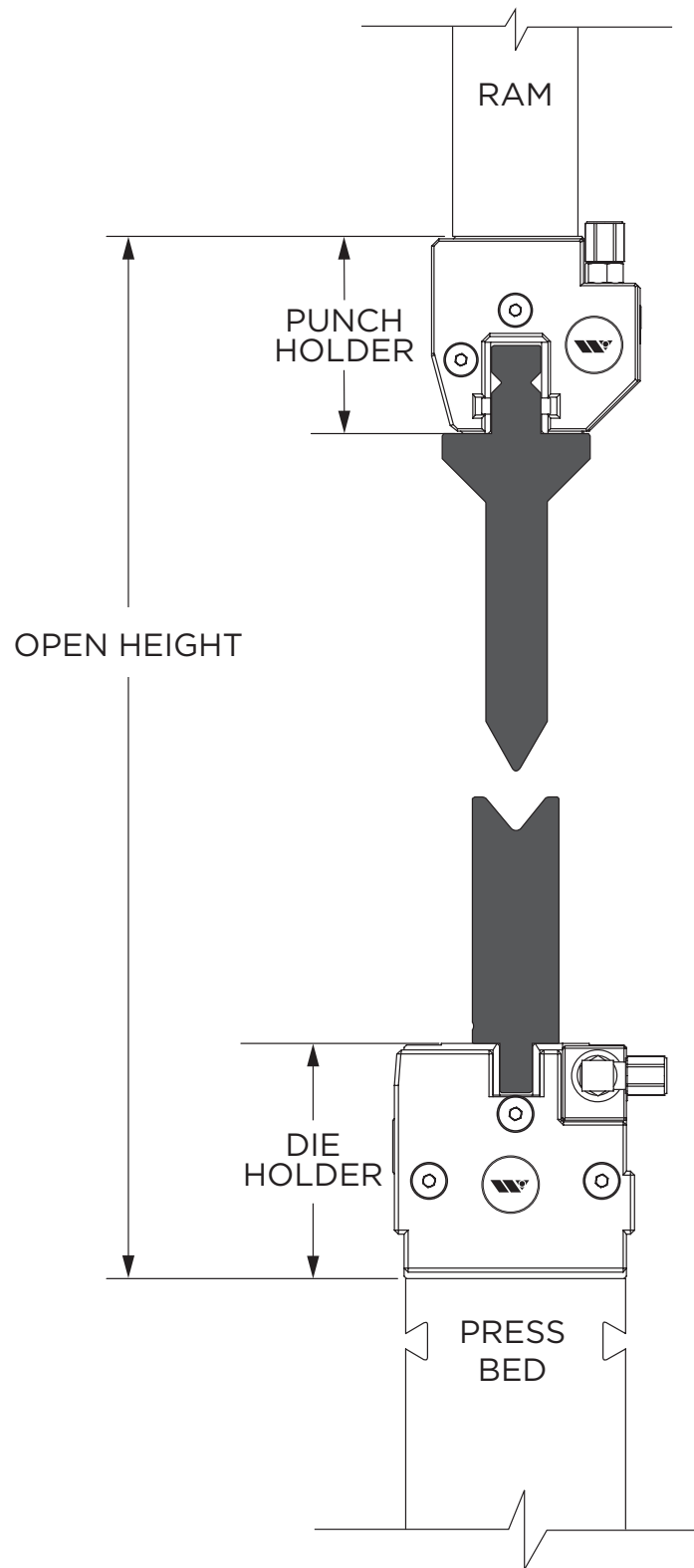

TIP MODIFICATIONS



Tip modifications are available in all styles and sizes.

Ear Piece

When ordering a special ear section from Wilson Tool, please indicate the dimensions on the diagram.

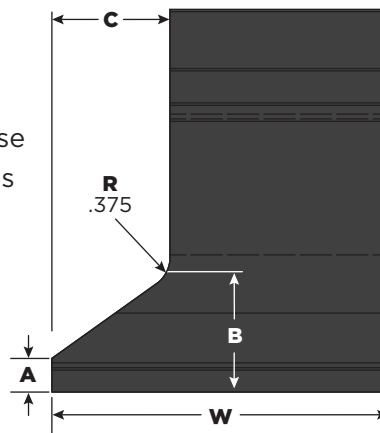

TOOL STORAGE

XTREME STORAGE CABINET



- Vertical configuration for drawer access from either side
- High-capacity drawers have a keyed lock and open smoothly with rolling casters
- Vertically adjustable trays maximize space for the height of tooling
- Adjustable tray inserts accommodate up to two rows of various tooling profiles. Removable center channel for larger tooling.
- Drawer trays hold punches in tip-up position
- Shallow top tray in each drawer for storing small items/hand tools
- Relatively small footprint allows for placement close to the machine

CUSTOM COLOR OPTIONS

051 Everest Blue	052 Classic Blue	055 Avalanche Blue	057 Midnight Blue	560 Glossy Sapphire Blue	041 Beige	061 Frost White	071 Light Gray	745 Modern Gray	072 Charcoal Gray
1025 Glossy EverGreen	208 Glossy Yellow	085 Sienna Orange	081 Flame Red	806 Glossy Carmine Red	815 Glossy Cranberry Red	091 Black	902 Glossy Black	741 Glossy Carbon Black	616 White

*Colors may differ slightly from those shown. Allow 15 working days lead time for custom colors.



Catalog Numbers

Xtreme Storage Cabinet Detail	5103W	5104W	5105W	5106W
Number of Drawers	3	4	5	6
Cabinet Height (outside dim.)	62" [1575mm]	62" [1575mm]	62" [1575mm]	62" [1575mm]
Width (left to right - outside dim.)	23" [585mm]	30" [762mm]	37" [940mm]	44" [1118mm]
Depth / Tool Space (front to back - inside dim.)	44" [1118mm]	44" [1118mm]	44" [1118mm]	44" [1118mm]
Number of Tool Trays	12	16	20	24
Total Length* of Tooling (1 tool/tray - inside dim.)	40' [12.1m]	53' [16.1m]	66.5' [20.2m]	80' [24.3m]
Total Length* of Tooling (2 tools/tray - inside dim.)	80' [24.3m]	106' [32.3m]	133' [40.5m]	160' [48.7m]

*Total length does not include available storage in the top trays.

ACCESSORIES

TOOL STORAGE

LAY-DOWN CABINET FOR PRESS BRAKE TOOLING

- 9 drawers for punches and dies lined with blue, industrial-strength, closed cell foam
- Lay down design displays laser markings and makes for easy identification of tools
- Heavy-duty construction with reinforced drawers for industry leading twist strength
- Solid steel construction
- Rated capacity of 3,600 lbs.
- Total weight capacity: 440 lbs. per drawer
- One-drawer-at-a-time integrated locking
- Retainer top with rubber mat
- Stationary cabinets have a removable kick-plate for fork lift transportation
- Mobile base option with side handle has heavy-duty casters and extended wheel base to prevent tipping
- Cabinets ship via freight truck

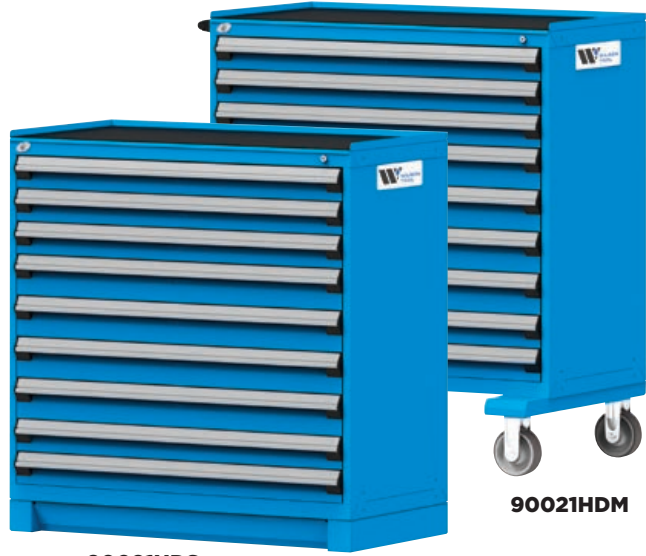

ACCESSORIES

Additional cabinets available — Contact our Tooling Technicians for pricing and lead times.

Part No.	Description	W x D x H	Drawer Sizes
9002IHDS	Stationary	48" x 27" x 49"	5 - 2.25" [57.1mm]
9002IHDM	Mobile	48" x 27" x 53.5"	4 - 3.25" [82.5mm]

Lead Time = 5 to 15 Days

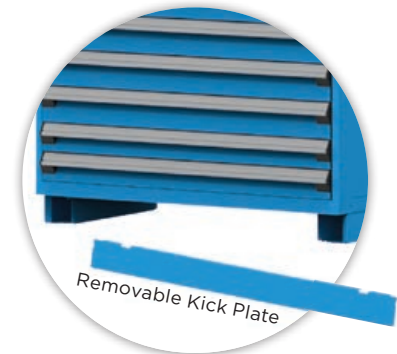

CUSTOM COLOR OPTIONS

051 Everest Blue	052 Classic Blue	055 Avalanche Blue	057 Midnight Blue	560 Glossy Sapphire Blue	041 Beige	061 Frost White	071 Light Gray	745 Modern Gray	072 Charcoal Gray
1025 Glossy EverGreen	208 Glossy Yellow	085 Sienna Orange	081 Flame Red	806 Glossy Carmine Red	815 Glossy Cranberry Red	091 Black	902 Glossy Black	741 Glossy Carbon Black	616 White

*Colors may differ slightly from those shown. Allow 15 working days lead time for custom colors.



TOOL STORAGE

TOOLING CART



**Part No.
990959**

- Cart Dimensions: 39"W x 27"D x 38"H
- 75 lb. drawer capacity; ball bearing slides with full drawer extension
- Heavy duty 6-inch casters, each with a 900 lb. capacity; 2 rigid and 2 swivels with brakes
- Max capacity of 54 linear feet; Max tool length of 36"
- 3-inch deep drawer for miscellaneous instrument and tool storage
- Wide wheel base helps prevent tip over
- Compatible with multiple styles of press brake tooling

MEASURING TOOLS

DIGITAL ANGLE CUBE



**Part No.
974119**



The compact size of the Digital Cube allows you to quickly read bend angles of work material. Real time display of angle comparison. Magnets on three sides. Self-rotating display for 180° readings.

HAND TOOLS

METRIC HEX KEY WRENCH SET

Metric 9 piece long arm set.
Contains: 1.5 x 77, 2 x 83,
2.5 x 90, 3 x 98, 4 x 106, 5 x 118,
6 x 137, 8 x 156, 10 x 170



Part No. 6105

SOFT FACE HAMMER

Polyurethane dead-blow hammer. Steel pellets inside hammer head impact a split second after the hammer face, reducing rebound.



Part No. 6106

MAGNET SQUARE

ON/OFF work holding magnet. 150 lb. [70 kg] of hold force. Size: [30] Square



Part No. 974150

GAUGING TOOLS

DIAL ADJUSTABLE SQUARING ARM

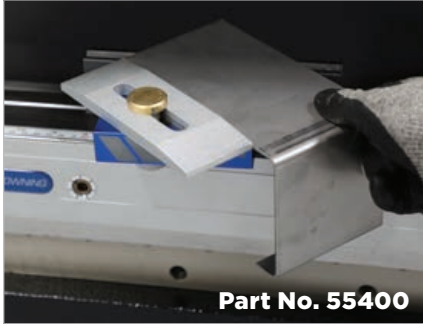

Infinite angle squaring arm with tool-free adjustment can be used as a left or right hand gauge. Significant magnetic holding power keeps the unit in place. Small enough to be out of the way, yet big enough to provide a sizable surface to rest the material being bent.

MAGNETIC SQUARING ARM

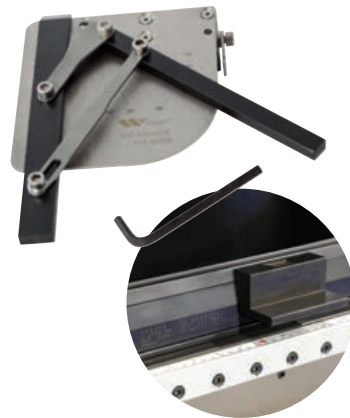

Increase bending accuracy with this simple hand tool. Suitable for any press brake die with a flat surface for easy attachment. Adjustable from 0° or 90° and is available in a left-handed or right-handed version.

Part No.	Description
42750L	Magnetic Squaring Arm LEFT
42750R	Magnetic Squaring Arm RIGHT
42750A	30° Die Adapter

MAGNETIC SQUARING BLOCK



Versatile, durable, 90° squaring block for left or right support and gauging. Strong magnets hold the lightweight tool in place while allowing for easy repositioning.

MAGNETIC GAUGE



Use for back gauging, gauging outside the frame of the brake, front gauging, or when the part doesn't quite work with part configuration.

Part No.	Description
988741	Blue Threaded Cap

MARK-FREE BENDING

URETHANE ROLLS — 6 in. x 100 ft.



Part No.	Thickness	Durometer	Description
42530	.015" [.4mm]	85A (Milky White)	<ul style="list-style-type: none"> • More elastic than blue • Well suited for deeper draw applications • Will not last as long as blue for 90° bends
42531	.030" [.8mm]		
42532	.022" [.56mm]	95A (Blue)	<ul style="list-style-type: none"> • A more ridged solution • Lasts considerably longer than the white options in many applications • Harder and less elastic than blue • Not suited for deeper draw applications

Note: This is not a good time to cheat the V-opening and make it smaller. Keep in mind you are filling the V-opening with two thicknesses of urethane so it would be safer to oversize the V-opening a bit. The larger the shoulder radius, the larger the V-opening relative to the material type and thickness, the longer the life will be realized.

PROTECTIVE FABRIC DRAPE



Forms a protective barrier between the sheet metal and the die shoulders during the bending process. Lasts 5-8 times longer than a urethane drape.

Part No.	Description
55335	12.5m [41'] length x 120mm [4.7"] width
55337	12.5m [41'] length x 240mm [9.5"] width
988156	3/8" x 1/2" Cylinder Magnet w/Blue Grip Cover

DRAPE HOLDER



Part No. 55338



Magnetic body provides quick, secure attachment to any press brake die or die holder. Hex head bolts allow for front-to-back adjustment of material placement and easy material swaps. Low-profile design helps avoid bulky rolls getting in the operator's way.

WILSON TOOL INTERNATIONAL HEADQUARTERS

12912 Farnham Avenue N, White Bear Lake, MN 55110, USA
800.445.4518 | **bending@wilsonstool.com**

Canada 800.268.4180 bending@wilsonstoolcanada.com
Mexico 001.800.741.2510 doblez@wilsonstool.com

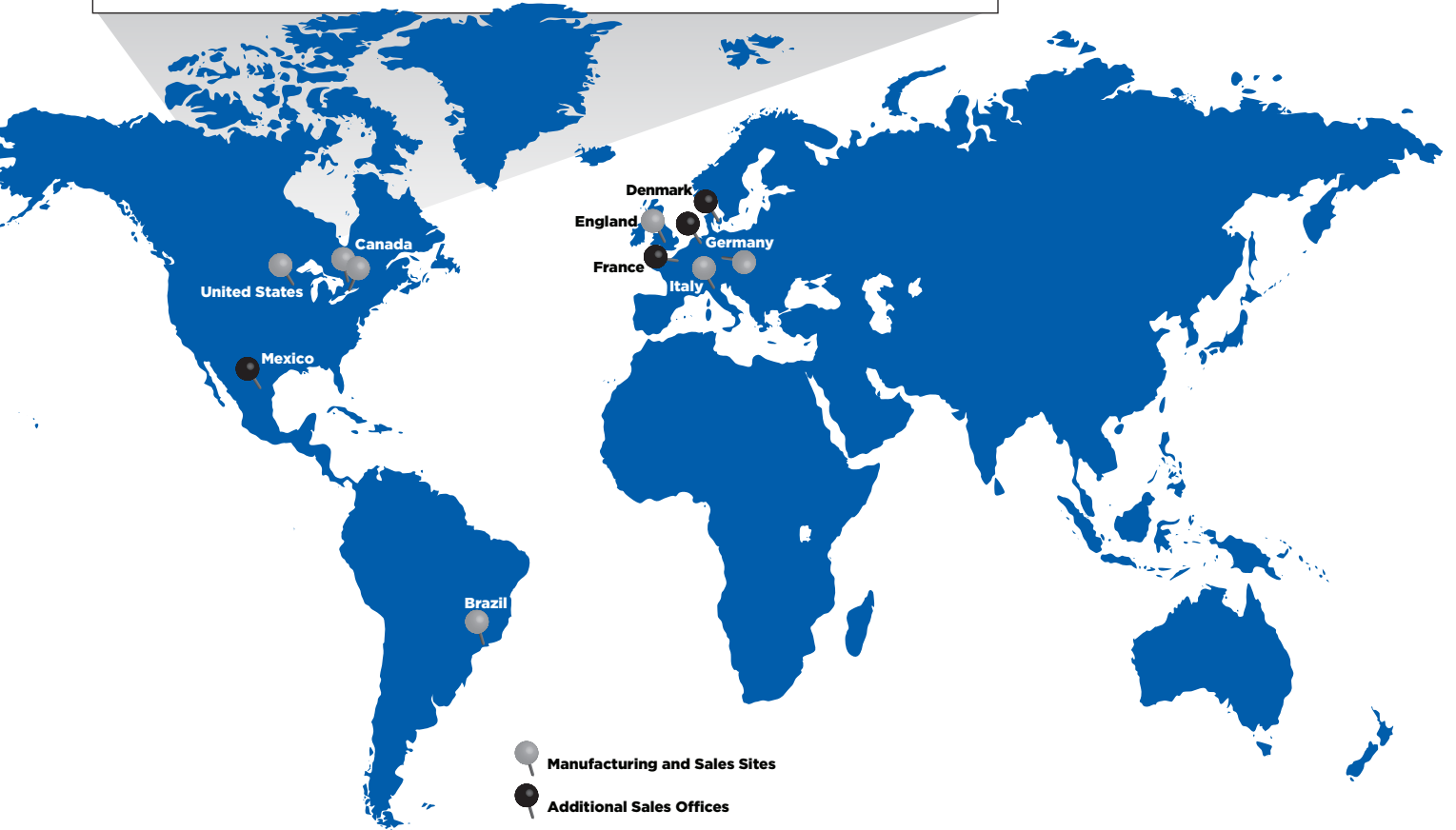

GUARANTEED TO OUTPERFORM

With Wilson Tool International, you're not just receiving tools — you're gaining a partner dedicated to your productivity, and products backed with a guarantee to outperform your current tooling.



B352C 2.2026